

Product portfolio

**We know washrooms.**  
For all your design and  
budget requirements.



**Venesta**

**We know washrooms.**  
After more than 120 years of innovation in partnership with our customers, we're still passionate about setting new standards of design, value, performance and reliability.

At Venesta, we live and breathe washrooms. Ever since the early days, innovation has been our inspiration, and product excellence our goal. With a commitment to setting the benchmark for design and performance, we've partnered with our clients in creating solutions that they can rely on to satisfy the most challenging and demanding of briefs.

Today, our expert knowledge and pioneering attitude have inspired our new range of commercial toilet cubicle and washroom systems. On the following pages you'll discover great product choice, value for money and uncompromising quality. As customer care is so important to us, you'll find we're breaking new ground in customer service too.

We invite you to see for yourself.

# We know our customers.

## From tailor-made design excellence to dedicated support and responsive service, everything we do is focused on you and what you need to get the job done.

### Your guarantee of quality

At Venesta, quality underscores everything we do. Our design team is dedicated to providing solutions that inspire, delight and perform superbly, even in the most demanding of environments.

All of our fittings are designed to suit our clients' specific requirements. Each component is considered in detail, in terms of both visual appearance and functionality. The same integrity applies in the way we select materials.

Our research and development team is continually raising the design benchmark and no product is launched without extensive testing. In fact, we've been at the forefront of industry invention for many years and have pioneered countless innovations.

### Durable and fit for purpose to suit your demands

Everyone expects a product that's fit for purpose but for Venesta, all of our products come with a rock solid 10-year guarantee. We make it our business to really understand your needs before providing the appropriate solution. That way we can be sure you're getting the right product for the job. Fit for purpose also means high standards of durability.

### Simple to install to make your life easier

Because we want to make your life as easy as possible, installation is at the forefront of our mind when we're creating new products. With simplicity built into every solution and thorough fixing instructions provided, we can ensure your washroom will be built and ready for use in the shortest of time frames. But don't forget, if you do experience any difficulties, our customer service team is here to resolve any issues quickly and efficiently.

### A team of experts focused on fulfilling your needs

At Venesta, we've built a team of people who are genuinely passionate about what they do. Many of us have been with the company for years and have built up a wealth of experience and product knowledge. We have CAD technicians to help with your drawings, project management professionals to ensure everything is on budget and on time, manufacturing experts who have a fine eye for detail and a friendly team that's committed to your total satisfaction.

### Equality Act 2010 compliant for your reassurance

At Venesta, we're an authority on Equality Act 2010 compliance. From access, to colours and finishes, we offer products that are fully compliant. What's more, because we understand the Equality Act 2010 inside out, we can provide an unrivalled level of support and advice, should you need it.

### The UK's first panel manufacturer to achieve 0% board waste to landfill

In 2019 we were extremely proud to announce that we achieved our target of 0% board waste going to landfill, with the help of our £1.2M state-of-the-art 1.75MW on-site biomass burner.

The heat generated from our burner provides heating to our entire manufacturing facility and office buildings, self-sufficiently, from waste offcuts.

As a manufacturer we're making the most of every portion of the materials that we use and are continually searching for ways to reduce energy consumption across all of our facilities. We know our responsibility and Venesta is totally committed to making a positive impact on the environment.



### 01 A friendly team of experts

We're genuinely passionate about what we do and enjoy sharing our wealth of experience and product knowledge with you.

### 02 A fine eye for detail

Our team is committed to your total job satisfaction, and that means getting every detail right, every time.

### 03 Our responsibility to the environment

The heat generated from our biomass burner provides heating to our entire manufacturing facility and office buildings from waste offcuts.

### 04 Quality materials

No product is launched without extensive testing and all materials are selected for quality and durability.

# We know good service.

## The quality of our products is only half the story. We know that excellent service can make all the difference to your satisfaction.

### Our 7-stage service plan

Whether it's a simple vanity unit or an extensive refit, you'll always find we go the extra mile to ensure you're happy. Here's our 7-stage service plan.

#### Stage 1 Specification

Our dedicated team of Specification Managers will help you choose the most cost effective and suitable products for your project without compromising on aesthetics and quality. To help you, our NBS specification writing service is available free of charge to guide you through all the detail. With our remote specification service, the process is quick and easy. Simply send over your drawings and your local Specification Manager will provide you with a comprehensive specification tailored to your project. Remember, whenever you need advice of any kind, just call our helpful sales team, who can also provide you with product literature and material samples.

#### Stage 2 Estimating

Our estimating service has never been stronger, and we are committed to delivering quotations on time. We pride ourselves on our attention to detail, so our comprehensive quotations always give the most detailed breakdowns of materials and prices. Don't forget, our dedicated technical helpline is here to give you technical support on all our products at any stage of the estimating and ordering process.

#### Stage 3 CAD

Once your order is placed, our highly skilled CAD Technicians will prepare layout drawings. At this stage, you'll be given a dedicated CAD Technician to work with you throughout your project. Everything from dimensions, colours and drawings can be sent for your approval prior to manufacture.

#### Stage 4 Manufacture and delivery

We're committed to delivering your order as soon as we possibly can, wherever you are in the world. With that in mind, we've invested £5m in state-of-the-art machinery to streamline our manufacturing process, making it more efficient than ever before. 100% on time, in full with no errors is our aim and we monitor our performance closely to ensure we can deliver on this.

#### Stage 5 Installation

Our highly responsive technical helpline is here to give you technical support throughout the installation process. It's worth remembering that although we're a supply only company, if you need fitting too, there are Accredited Installers we can recommend who have vast experience installing our products. Accredited Installers undergo a rigorous training and approval process so you can be assured of a top quality job.

#### Stage 6 After sales support and spares

Once your products have been delivered, we'll give you your own dedicated point of contact to efficiently deal with all your after sales needs. Attentive and highly empathetic to your needs, they'll ensure you're completely happy at all times with our service.

#### Stage 7 Spares website

Our spares website has been created to make it as easy as possible for you to purchase spare items for your Venesta products. Whether it's a toilet cubicle lock, a pedestal leg, headrail end caps, washroom cubicle hinges or door buffers, it's easy to find what you are looking for on our Venesta spare parts website. You'll find everything you need at [www.venesta-spares.co.uk](http://www.venesta-spares.co.uk).

One final thing, at Venesta, we appreciate customer feedback; it helps us to ensure we can continue to improve what we do in line with your needs. So, if you have any comments on our products or service, we want to hear them. You can call us on 01474 353333.

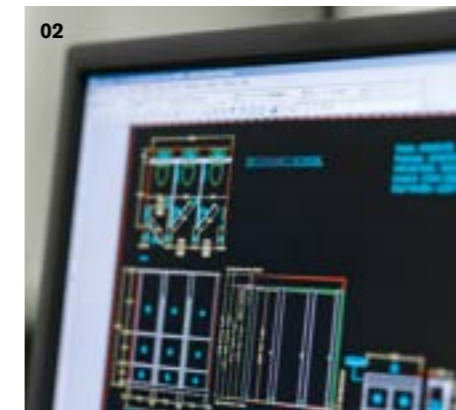

#### 01 Sample service

Our helpful sales team can provide you with product literature and samples.

#### 02 Technical drawings

Everything from dimensions, colours and drawings can be sent for your approval prior to manufacture.

#### 03 Dedicated technical helpline

When you're ready to specify, our dedicated technical helpline offers you all the technical support you need.

#### 04 Design team

A Specification Manager will talk through your washroom requirements to help you choose the most suitable products for your project.

# We know choice. We make washrooms to suit all your specification needs, however demanding.

Created by our team of talented designers, the Venesta range brings together toilet cubicles, pre-plumbed washroom systems, panelling, vanity units and washroom accessories. To make specifying easy, we've categorised our products into these key areas:

## V1

### Low-cost cubicles

Affordable style is our V1 signature. We've created each product to give you great value without compromising on quality or functionality.



## V2

### Standard cubicles

With an extensive choice of colours and fittings, our V2 standard range offers unrivalled performance and quality at an affordable price.



## V3

### Premium cubicles

At Venesta, we love design and V3 is our premium range for style-led environments. You can expect superb craftsmanship, the latest finishes and on-trend colours.



### Specialist ranges

Our specialist ranges feature a collection of designs that cater for more specific requirements, with designs for education, healthcare, sports and leisure centres.



### Panelling

We created the very first pre-plumbed system and we've been evolving our range ever since. We can offer you three choices according to your needs and budget: Vepps, Frameduct and Rapiduct.



### Mirrors, vanities and accessories

Whatever your budget or environment, we have a great choice of Mirror Box Units, vanity units and accessories to complement your washroom.



# We know washroom solutions. Choice at your service.

## V1 Low-cost cubicles

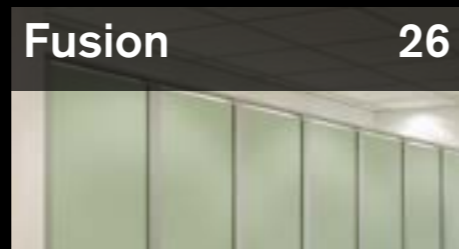

V1

## V2 Standard cubicles



V2

## V3 Premium cubicles

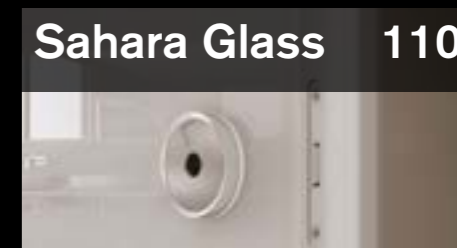
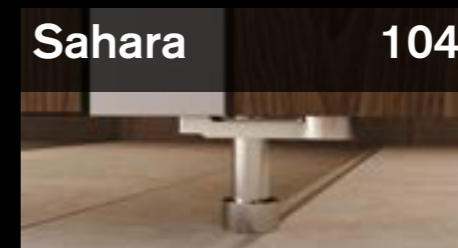
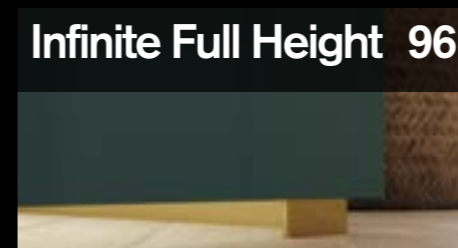
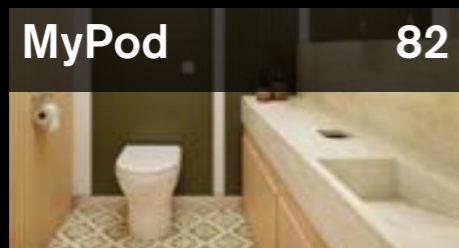

V3

## Specialist ranges

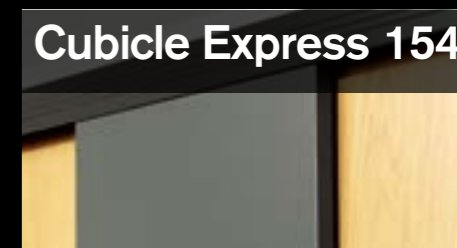
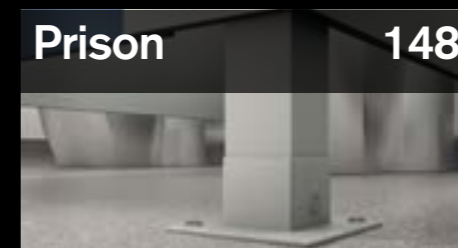
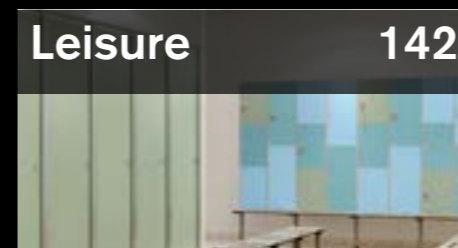
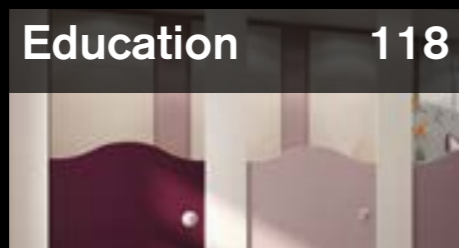

Specialist ranges

## Panelling



Panelling

## Mirrors, vanities and accessories

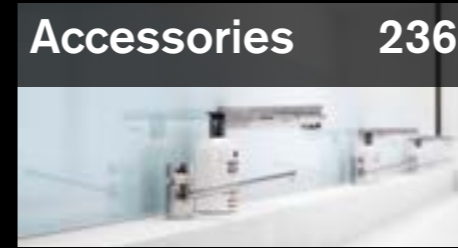
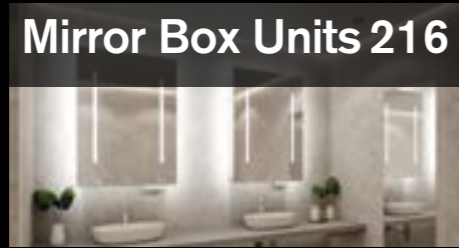

Mirrors, vanities and accessories

# V1

**We know cubicles.**  
V1 delivers highly functional, affordable style that's designed to suit both your budget and your specification needs. What more could you ask for?

# Your low-cost range with quality and style built in.

At Venesta, we believe you shouldn't have to compromise on quality just because you're choosing a low-cost solution. So our design team has risen to the challenge, bringing you the best quality finishes and fittings at the best price to suit your budget.

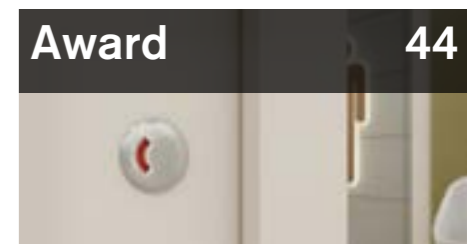
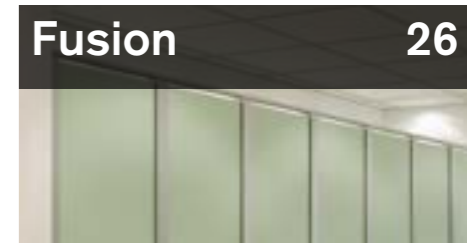

**Unity** Simple and striking: that's Unity. This clean, modern design is the UK's most economical, well designed flush cubicle range. Whatever the environment, Unity's 'floating' flush front always makes a big impact.





# Unity



01

**01** Slimline profile headrail in satin anodised aluminium finish. 3 part fixing system allowing cubicles to finish only 20mm below ceiling height.

**02** Pedestals are fitted to partitions to give the range its floating appearance.

**03** Black effect fitting.

**04** Brass effect fitting.

**05** Bronze effect fitting.



02

**Main image**  
Unity ColourCoat cubicles in Orange (RAL2008) with Solid Surface H2 profile vanity.

See p24-25 for Unity technical specifications.

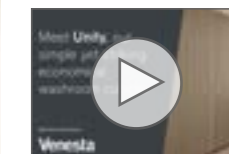

See why Unity is our most popular cubicle by watching our dedicated video on our YouTube channel.



03



04



05

V1

# Unity

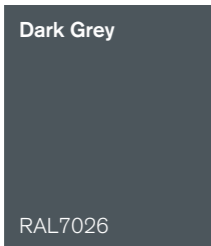
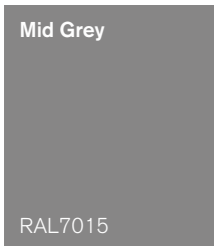
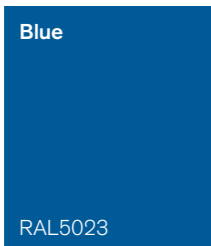
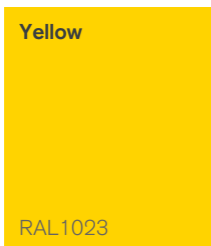

**ColourCoat**  
ColourCoat is our vibrant range of contemporary spray painted colours. Doors and pilasters are sprayed with a coat of primer and finished with 20% gloss pigmented lacquer.

**ColourCoat High Gloss**  
ColourCoat High Gloss is our highly reflective, spray painted colour finish. Doors and pilasters are sprayed with a coat of primer and finished with 80% gloss pigmented lacquer.

**01 Pedestals** are fitted to partitions to give the range its floating appearance.

**Main image**  
Unity ColourCoat cubicles in Purple (RAL4006) with Solid Surface H3 profile vanity.

See p24-25 for Unity technical specifications.



**Key features**

- Minimal look with clean lines
- Flush fronted with a floating appearance
- Satin anodised aluminium and stainless steel fittings
- Full-height and increased privacy options available
- Choose from 34 standard laminate colours or 10 RAL finishes for ultimate design flexibility
- Optional choice of black, brass or bronze effect cubicle hardware for ultimate design flexibility

## Case Study Capital One Head Office

Capital One recently turned their attention to breathing new life into their washrooms to give their staff the very best facilities throughout their office.

Capital One's previous washrooms were dated and in need of a complete overhaul. We were pleased to work alongside Nottingham-based contractors Rotunda Construction to bring Capital One's employees new stylish, modern and easy to maintain washrooms.

Our Unity toilet cubicles were specified in all six of the new washroom areas at Capital One. With setback satin anodised aluminium pedestals fixed to the partitions, Unity has a floating appearance which makes a huge impact in these modern washrooms.

The cubicles were specified in Solid Grade Laminate (SGL) which is an impact and scratch resistant material so will withstand heavy usage in Capital One's busy office. SGL is impervious to water, meaning the cubicles can be regularly cleaned, so that excellent hygiene standards are maintained.

Capital One had a choice of 34 laminate finishes for their Unity toilet cubicles, and opted for our luxurious wood effect 'Dark Walnut' laminate, which complemented the décor of the rest of the rooms.

The minimally designed, flush-fronted cubicles feature sleek satin anodised aluminium flip indicator bolts, faceplates and internal mortice locks, which complement the contemporary design of the cubicles. The indicator bolts offer a cleverly designed emergency release mechanism, so access to locked cubicles can be gained without causing damage to the lock or having to remove the door in the event of an emergency.

**Read the full case study at [www.venesta.co.uk](http://www.venesta.co.uk)**

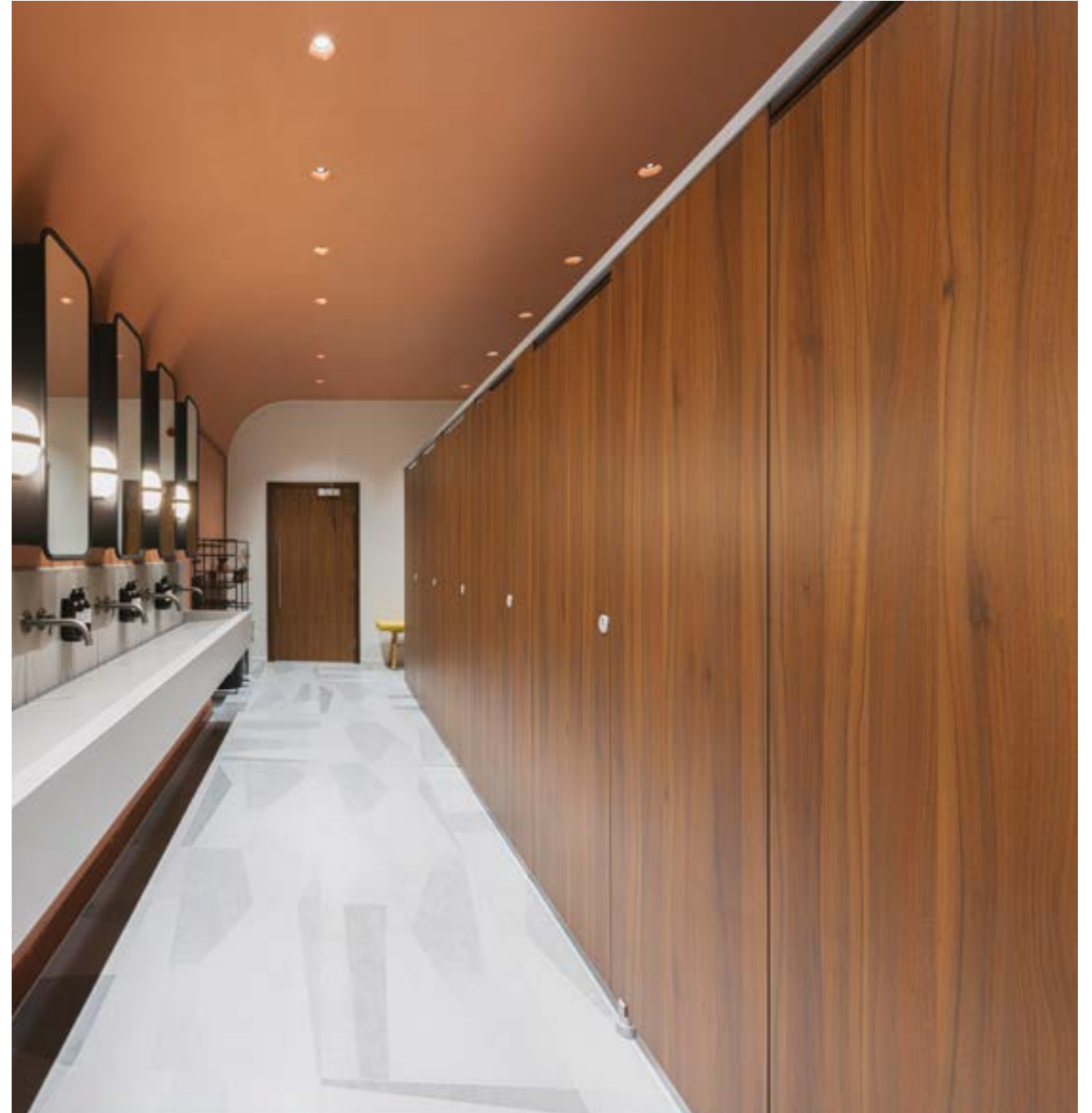

# Technical Specifying Unity

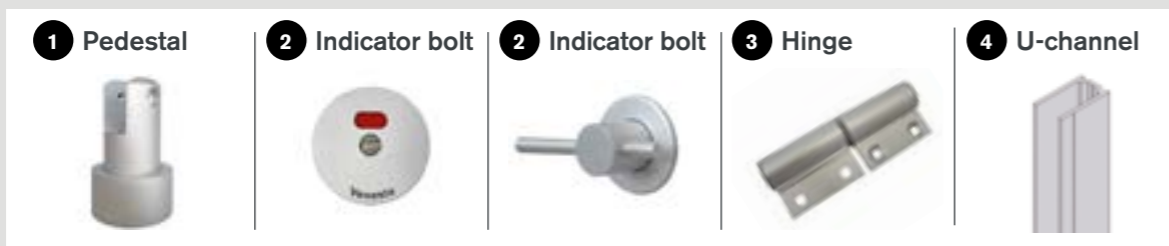
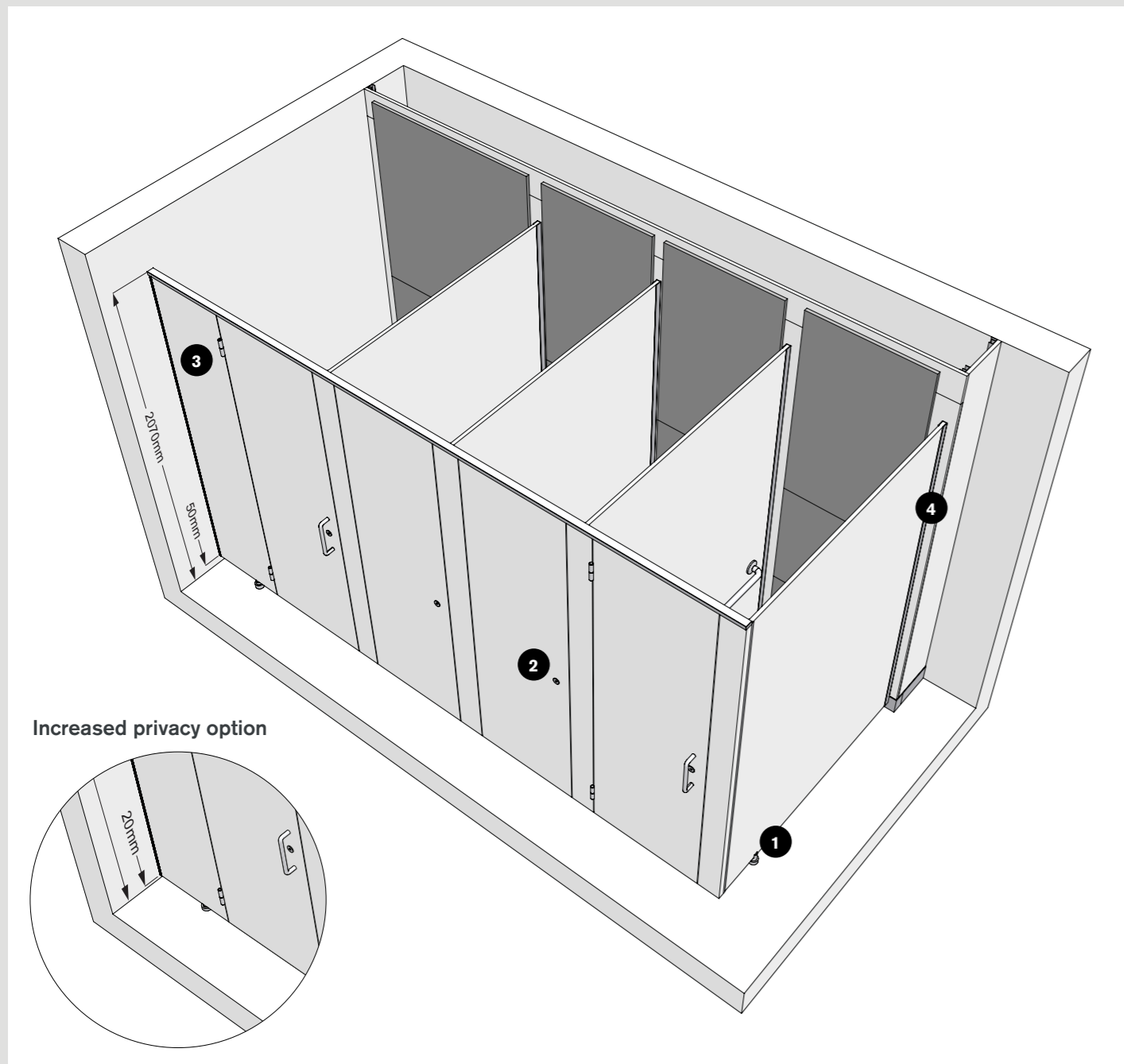

## Dimensions

<b>Unity</b>	
<b>Overall height</b>	
HPL	2070mm
SGL	2065mm
ColourCoat	2070mm
High Gloss	2070mm

<b>Maximum depth</b>	
HPL	2084mm
SGL	1921mm
ColourCoat	2084mm
High Gloss	2084mm

<b>Floor clearance</b>	50mm
------------------------	------

<b>Minimum ceiling clearance</b>	20mm
----------------------------------	------

<b>Unity Full Height</b>	
<b>Maximum height</b>	
HPL	2835mm
SGL	2818mm
ColourCoat	2835mm
High Gloss	2835mm

<b>Maximum depth</b>	
HPL	2084mm
SGL	1921mm
ColourCoat	2084mm
High Gloss	2084mm

<b>Floor clearance</b>	50mm
------------------------	------

<b>Minimum ceiling clearance</b>	20mm
----------------------------------	------

<b>Unity Full Height Privacy</b>	
<b>Maximum height</b>	
HPL	2805mm
SGL	2788mm
ColourCoat	2805mm
High Gloss	2805mm

<b>Maximum depth</b>	
HPL	2035mm
SGL	1921mm
ColourCoat	2035mm
High Gloss	2035mm

<b>Floor clearance</b>	20mm (cubicle standard height will drop by 30mm and partitions will sit on privacy skirting with end cap).
------------------------	--

<b>Minimum ceiling clearance</b>	20mm
----------------------------------	------

## Performance

Available in four material options, Unity is suitable for every type of wet or dry environment, allowing you to specify the most appropriate option to meet the site requirements and your budget.

**HPL**  
For more heavily used washrooms, panels are heat, scratch, impact and cigarette burn resistant. Moisture-resistant chipboard faced with High Pressure Laminate. Edges with matching lipping. Doors and pilasters are 35mm nominal thickness with an MDF core, partitions are 19mm nominal thickness.

**SGL**  
Solid Grade Laminate is extremely resistant to impact and all surfaces are impervious to water. Panels are 13mm nominal thickness with polished black radiused edges.

**ColourCoat**  
Panels have an MDF core. Doors and pilasters are sprayed with a coat of primer and finished with 20% gloss pigmented lacquer. Doors and pilasters are 35mm nominal thickness, partitions are 18mm nominal thickness.

**ColourCoat High Gloss**  
Panels have an MDF core. Doors and pilasters are sprayed with a coat of primer and finished with 80% gloss pigmented lacquer. Doors and pilasters are 35mm nominal thickness, partitions are 18mm nominal thickness.

## Detailing

**Panels and doors**  
Available in HPL, SGL, ColourCoat and ColourCoat High Gloss.

**Colour finish**  
**HPL and SGL**  
34 colours from the standard range.  
**ColourCoat and ColourCoat High Gloss**  
10 colours.

**Hardware**  
Satin anodised aluminium and stainless steel. Optional choice of black, brass or bronze effect coatings.

**Edge treatment**

**HPL**  
Matching lipping  
**SGL**  
Polished black radiused edge.  
**ColourCoat**  
Edges sprayed with a coat of primer and finished with 20% gloss pigmented lacquer.  
**ColourCoat High Gloss**  
Edges are sprayed with a coat of primer and finished with 80% gloss pigmented lacquer.

**Headrail**

Slimline aluminium profile headrail in satin anodised finish. 3 part fixing system which allows stalls to finish only 20mm below ceiling height.

**Hardware**

**Indicator bolt**  
Satin anodised aluminium flip indicator bolt with emergency release facility and faceplate. 35mm doors have an internal mortice lock. All with concealed fixings.  
**Hinge**  
Satin anodised aluminium modular rise and fall flag hinge, set to fall open or closed.

**Pedestal**  
50mm FC: Adjustable satin anodised aluminium pedestal with a ± 5mm tolerance.  
20mm FC: In-line stainless steel pedestal with a tolerance 5mm. Satin anodised aluminium partition skirting.

**Fixings**  
Partition to wall: Satin anodised aluminium U-channel.  
Pilaster to partition: Satin anodised aluminium U-channel.  
Pilaster to wall: Satin anodised aluminium L-angle 13mm (SGL), E-channel 36mm (HPL, CC and CCHG).

**Accessories**  
Coat hooks and toilet roll holders available. Optional choice of black, brass and bronze effect fittings.

**Fusion** Bringing together cutting edge design, unrivalled performance and surprising affordability, Fusion is an innovation all of its own. With an ultra-strong metal frame and slimline pilasters that fix to the floor for added rigidity, Fusion combines strength and modernity in equal measure.

Fusion



# Fusion



**01** Floor fixed pilasters for added rigidity.

**02** Discreet, slimline indicator bolt faceplate with emergency release facility.

See p34-35 for Fusion technical specifications.

**Main image**  
Fusion SGL cubicles with lockers and benching.

# Fusion

**Main image**  
Fusion MFC cubicles  
and Solid Surface WT4  
profile washtrough.

See p34-35 for Fusion  
technical specifications.

## Key features

- Full satin anodised aluminium frame
- Floor fixed pilasters for added rigidity
- Uniform slimline pilasters and headrail
- Contemporary minimal design
- Sleek satin anodised aluminium fittings
- Complete colour flexibility
- Economical
- Full-height option available for increased privacy



## Case Study Dover Castle

**Our metal-framed Fusion toilet cubicles bring English Heritage site Dover Castle cutting-edge washroom design and unrivalled performance.**

Steeped in history, Dover Castle has stood on Kent's iconic White Cliffs for nine centuries. It's one of the most famous European fortresses, with an important place in British History.

With over 250,000 people visiting the castle every year, the English Heritage site required durable and hardwearing washroom solutions to withstand the demands of such high footfall.

Our ultra-strong metal-framed toilet cubicle range, Fusion, was specified for Dover Castle's washrooms. The metal frame fixes directly into floor mounting blocks, making Fusion toilet cubicles strong and secure.

The cubicles were manufactured in Solid Grade Laminate (SGL) thanks to its durable and impact resistant properties. SGL is the ideal material for high footfall washroom environments as it's completely waterproof so can withstand regular and intensive cleaning regimes, to ensure that the highest levels of hygiene are met at all times.

Dover Castle had 34 on-trend laminate colours to choose from for their toilet cubicles. The female cubicles were finished in 'Merlot', while 'Duck Egg' was the choice for the male cubicles; with all partitions in neutral and complementing 'Cloud'.

**Read the full case study at [www.venesta.co.uk](http://www.venesta.co.uk)**



# Technical Specifying Fusion

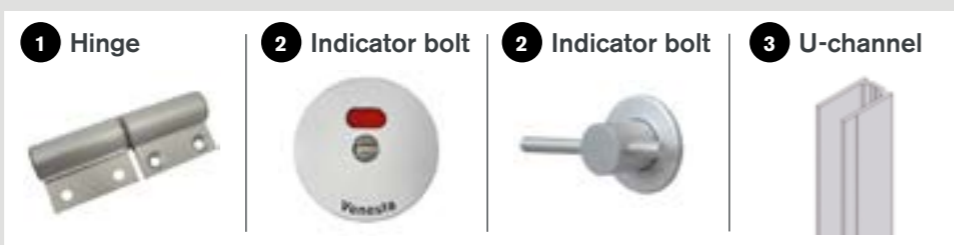
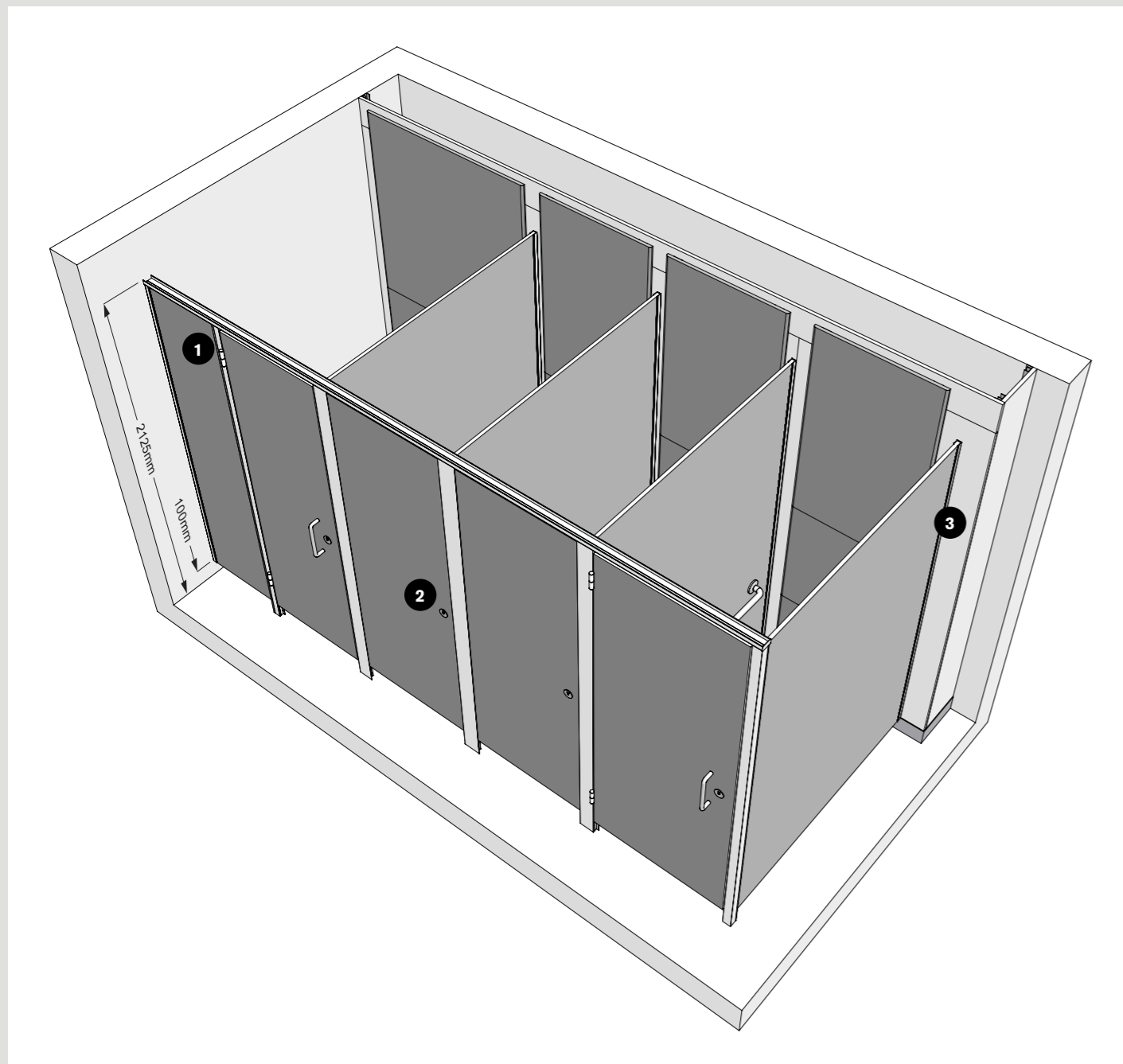

## Dimensions

### Fusion

<b>Overall height</b>	
MFC	2125mm
HPL	2125mm
SGL	2125mm

<b>Maximum depth</b>	
MFC	2090mm
HPL	2060mm
SGL	1930mm

<b>Floor clearance</b>	100mm
------------------------	-------

<b>Minimum ceiling clearance</b>	150mm
----------------------------------	-------

<b>Fusion Full Height</b>	
<b>Maximum height</b>	
MFC	2895mm
HPL	2895mm
SGL	2895mm

<b>Maximum depth</b>	
MFC	2090mm
HPL	2060mm
SGL	1930mm

<b>Floor clearance</b>	100mm
------------------------	-------

<b>Minimum ceiling clearance</b>	150mm
----------------------------------	-------

## Performance

Available in three material options, Fusion is suitable for every type of wet or dry environment, allowing you to specify the most appropriate option to meet the site requirements and your budget.

### MFC

For dry environments with low risk of vandalism. Panels are manufactured from 19mm nominal thickness high performance moisture-resistant Melamine Faced Chipboard. Edges with matching lipping.

### HPL

For more heavily used washrooms, panels are heat, scratch and impact resistant. Manufactured from moisture-resistant chipboard faced with High Pressure Laminate, panels are 19mm nominal thickness. Edges with matching lipping.

### SGL

Solid Grade Laminate is extremely resistant to impact and all surfaces are impervious to water. Panels are 13mm nominal thickness with polished black radiused edges.

## Detailing

### Panels and doors

Available in MFC, HPL and SGL.

### Colour finish

**MFC, HPL and SGL**

34 colours from the standard range.

### Cubicle hardware

Satin anodised aluminium.

### Edge treatment

**MFC and HPL**

Matching lipping.

**SGL**

Polished black radiused edge.

### Headrail

Satin anodised aluminium.

### Pilasters

High strength, slimline extruded satin anodised aluminium, incorporating moulded channel to secure partition.

### Cubicle hardware

#### Indicator bolt

Satin anodised flip indicator bolt with circular face plate, emergency release facility and matching keep.

#### Hinge

Rise and fall satin anodised aluminium hinges with adjustable self-lubricating cams to allow the door to fall closed, open or ajar. Lift off hinge to allow emergency access.

#### Pedestal

No pedestal required as the pilasters extend to floor level and are fixed to floor mounting blocks.

#### Fixings

Partition to wall: Continuous satin anodised aluminium U-channel.

### Accessories

Coat hooks and toilet roll holders available.

**Titan Living up to its name, Titan boasts a full-height design with low floor clearance for privacy and partitions with rigid wall channels, for strength where you need it most.**



# Titan

Rigid wall channels, aluminium headrails and floor-to-ceiling pilasters set into unique aluminium shoes makes Titan substantial and stable. With minimal floor and ceiling clearances, it provides maximum privacy, ideal for unisex washroom facilities.



01



02

01 Unique satin anodised aluminium shoes.

02 Satin anodised aluminium headrail.

See p42-43 for Titan technical specifications.

**Main image**  
Titan SGL cubicles in Gunmetal, Solid Surface vanity top in Elgon, 400mm Active Lockers and SGL benching both in Lime.

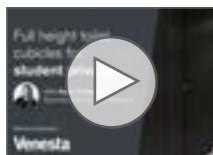

Full-height cubicles offer increased privacy for users. Watch our dedicated video on our YouTube channel.



- Key features**
- Floor to ceiling cubicles guarantee total privacy for users
  - Partition privacy skirting channel for 0mm gaps under partitions
  - Suitable for wet and dry environments
  - Unique satin anodised aluminium shoe
  - Wall channels for additional rigidity
  - Emergency release indicator bolts
  - Anti-finger trap hinges as standard

## Case Study The Leigh Academy

“The cubicles are what we’re best pleased with; they’re well made and will stand the heavy flow of traffic through them. Users have been pleased to see the transformation of old tired facilities to a bright inviting area.”

Nicholas Campbell, Site Manager at The Leigh Academy.

After 11 years since the reconstruction of The Leigh Academy’s original school buildings, the washrooms had become tired and were in need of rejuvenation. The thoughtful design of the school provides inspirational spaces for students and staff, so it was crucial that the new washrooms would uphold existing standards, whilst taking into consideration respect for student privacy, ease of supervision and quality.

The academy expressed a desire to remove doors upon entry to all toilet facilities, to act as a deterrent against anti-social behaviour. This was possible with our Full Height Titan cubicle range, providing maximum privacy whilst maintaining the integrity of student safety with emergency access features.

Titan has a minimal floor clearance of just 10mm, meaning no one can peep under or over cubicle doors, further reducing opportunities for bullying. In the event of an emergency, staff can release doors with our rapid release indicator bolts, without having to remove doors or cause damage to the cubicles.

The use of Solid Grade Laminate (SGL), specified in a light grey colour, has also helped to keep maintenance efforts low. The smooth surface of SGL is easy to clean and is totally waterproof so it can endure regular cleaning. With the help of robust fittings it is also impact, heat and scratch-resistant.

Read the full case study at [www.venesta.co.uk](http://www.venesta.co.uk)



# Technical Specifying Titan

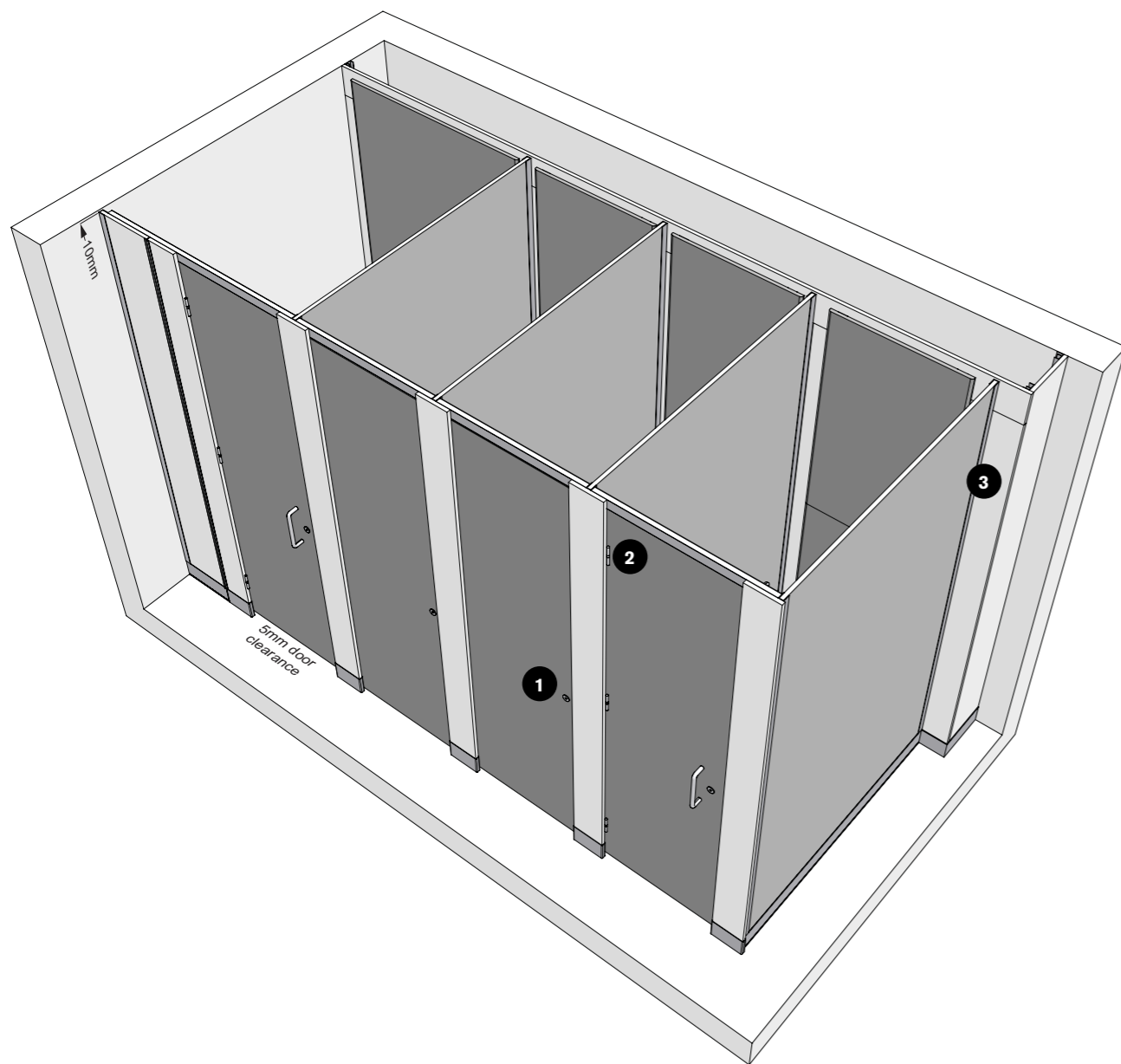

## Dimensions

<b>Maximum height</b>	
MFC	2790mm
HPL	2790mm
SGL	2790mm
<b>Maximum depth</b>	
MFC	2019mm
HPL	2019mm
SGL	1921mm
<b>Floor clearance</b>	
5mm at doors	
0mm at partitions and pilasters	
<b>Minimum ceiling clearance</b>	
10mm	

## Performance

Available in three material options, Titan is suitable for every type of wet or dry environment, allowing you to specify the most appropriate option to meet the site requirements and your budget.

**MFC**  
For dry environments with low risk of vandalism. Panels are manufactured from 19mm nominal thickness high performance moisture-resistant Melamine Faced Chipboard. Edges with matching lipping.

**HPL**  
For more heavily used washrooms, panels are heat, scratch and impact resistant. Manufactured from moisture-resistant chipboard faced with High Pressure Laminate, panels are 19mm nominal thickness. Edges with matching lipping.

**SGL**  
Solid Grade Laminate is extremely resistant to impact and all surfaces are impervious to water. Panels are 13mm nominal thickness with polished black radiused edges.

## Detailing

**Panels and doors**  
Available in MFC, HPL and SGL.

**Colour finish**  
**MFC, HPL and SGL**  
34 colours from the standard range.

**Cubicle hardware**  
Satin anodised aluminium.

**Edge treatment**  
**MFC and HPL**  
Matching lipping.  
**SGL**  
Polished black radiused edge.

**Headrail**  
Easy to fix, one piece construction high strength extruded satin anodised aluminium L-angle headrail.

**Cubicle hardware**  
**Indicator bolt**  
Satin anodised aluminium slide operated bolt with circular faceplate and emergency release facility. Faceplate and keep with concealed fixings.

**Hinge**  
Satin anodised aluminium rise and fall anti-finger trap hinge. Outward opening hinge option available.

**Pedestal**  
Unique satin anodised aluminium shoe.

**Fixings**  
Partition to floor: Unique satin anodised aluminium skirting channel with height and appearance matching pilaster shoe.

Partition to wall: Satin anodised aluminium U-channel.  
Pilaster to partition: Satin anodised aluminium U-channel.  
Pilaster to wall: Satin anodised aluminium U-channel.

**Accessories**  
Coat hooks and toilet roll holders available.

**Award** Versatile, economical and easy to assemble, Award gives you a tried and tested bespoke solution that works equally well in wet or dry environments.



# Award



## Award



01

**01** Pedestals are set back on partitions for floating appearance.

**02** Satin anodised aluminium indicator bolt faceplate.

See p50-51 for Award technical specifications.

### Main image

Award HPL cubicles in Suede and Olive with satin anodised aluminium fittings. Vepps panelling in Olive and Suede with Langley wall hung WCs, Marden Waterless urinals and Electroflo urinal sensors.



02

### Key features

- Simple installation
- Easy grip indicator bolts with emergency release facility
- Anti-finger trap hinges as standard
- Economical
- Suitable for dry and wet environments with shower curtain track option available
- A choice of 34 on-trend finishes for total design flexibility

## Case Study Wimbledon Chase Primary School

**Versatile and robust Award toilet cubicles were specified due to the unrivalled safety features that come as standard.**

Rated 'Outstanding' by Ofsted since 2012, Wimbledon Chase Primary School teaches over 700 pupils aged 3-11. It offers an inclusive environment where individuality and diversity is celebrated and kindness and respect is instilled in every child.

The school's washroom facilities were in need of a complete overhaul. Accredited Installers, G Haslehurst Builders, were appointed to reconfigure the space which included the installation of contemporary, reliable and easy to maintain washroom systems, all in good time.

Versatile and robust Award toilet cubicles were specified due to the unrivalled safety features that come as standard. Anti-tamper fixings and emergency release indicator bolts make Award a popular choice for schools.

These cubicles will stand the test of time thanks to the heat, scratch, impact and water resistant Solid Grade Laminate (SGL) coreboard material specified.

A fun, colourful washroom has been created by specifying the cubicle doors in Golden, Lime, Rouge and Pacific, while contrasting Gunmetal pilasters and partitions complement the modern décor of the room perfectly.

**Read the full case study at [www.venesta.co.uk](http://www.venesta.co.uk)**



# Technical Specifying Award

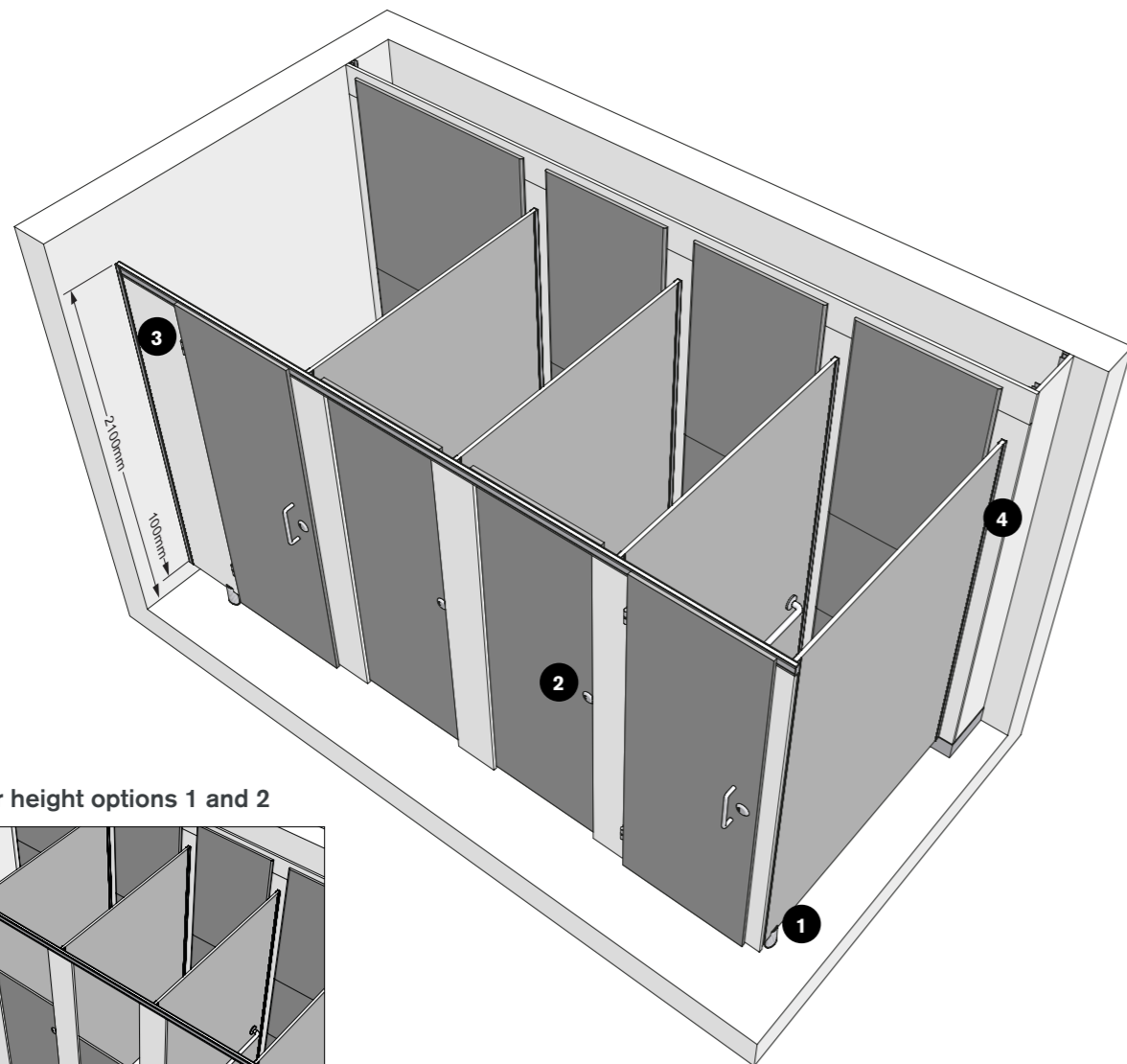

Children's door height options 1 and 2

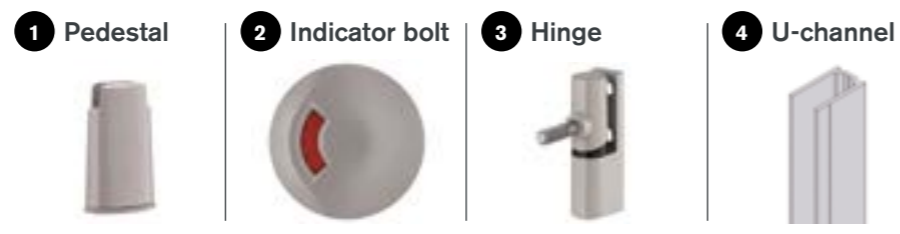
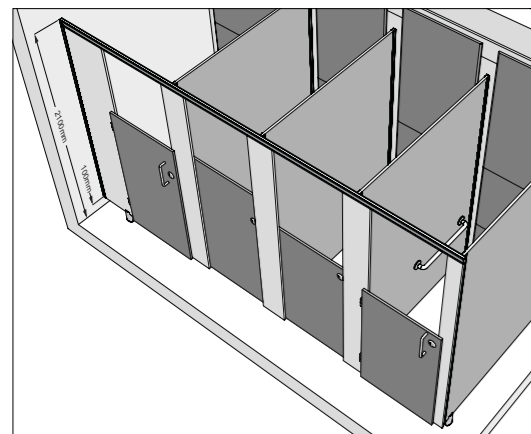

## Dimensions

### Overall height

2100mm

### Door height options

Standard	2000mm
Children's option 1	1300mm
Children's option 2	1100mm

### Maximum depth

MFC	2097mm
HPL	2057mm
SGL	1921mm

### Floor clearance

100mm

## Performance

Available in three material options, Award is suitable for every type of wet or dry environment, allowing you to specify the most appropriate option to meet site requirements and your budget.

### MFC

For dry environments with low risk of vandalism. Panels are manufactured from 19mm nominal thickness high performance moisture-resistant Melamine Faced Chipboard. Edges with matching lipping.

### HPL

For more heavily used washrooms, panels are heat, scratch and impact resistant. Manufactured from moisture-resistant chipboard faced with High Pressure Laminate, panels are 19mm nominal thickness. Edges with matching lipping.

### SGL

Solid Grade Laminate is extremely resistant to impact and all surfaces are impervious to water. Panels are 13mm nominal thickness with polished black radiused edges.

## Detailing

### Panels and doors

Available in MFC, HPL and SGL.

### Colour finish

**MFC, HPL and SGL**  
34 colours from the standard range.

### Cubicle hardware

Light Grey ABS, satin anodised aluminium or satin anodised effect powder coated zinc.

### Edge treatment

**MFC and HPL**

Matching lipping.

**SGL**

Polished black radiused edge.

### Headrail

Rigid satin anodised aluminium headrail with matching end cap.

### Cubicle hardware

#### Indicator bolt

Easy grip sliding bolt with emergency release facility and concealed fixings. Available in satin anodised effect powder coated zinc or Light Grey ABS.

#### Hinge

Anti-finger trap satin anodised aluminium rise and fall butt hinge. Outward opening hinge option available.

#### Pedestal

Height adjustable for uneven floors, with concealed fixings, available in Light Grey ABS or satin anodised effect powder coated zinc. Where possible, pedestals are located on partitions to give a floating appearance.

#### Fixings

Partition to wall: Continuous satin anodised aluminium U-channel.  
Pilaster to partition: Continuous satin anodised aluminium U-channel.  
Pilaster to wall: Continuous satin anodised aluminium U-channel.

### Accessories

Coat hooks and toilet roll holders available.

# V2

**We know cubicles.**  
For quality, style and durability, V2 is your promise of innovation at affordable prices. With our trademark attention to detail, stylish good looks and versatility, we've created a range that satisfies time and time again.

**Your choice for colours and fittings.**  
 A faultless combination of style and functionality, V2 is our hugely popular mid-range that promises you maximum colour possibilities and a superb selection of the latest fittings.



System M 56



Centurion 68



**System M** is a unique, robust toilet cubicle range with a patented, simple to operate, rapid release outward opening door system that provides optimal emergency access.

system M



## System M

System M has been designed to comply with the Document M regulation, for access to and use of buildings, while maintaining attractive aesthetics. System M has a proven track record of being able to cope with the demands of constantly used washrooms in some of the busiest airports in the world, including London Heathrow and Gatwick. This optimal emergency access cubicle is suitable for all high traffic environments, in particular airports, retail outlets and public buildings, such as schools and hospitals.



**01** Pivoting pilasters allow easy access with quick release system.

**02** Release facility allows a normally inward opening door to be opened outwards without causing damage to the cubicle.

### Main image

London Stansted Airport featuring System M.

See p66-67 for System M technical specifications.

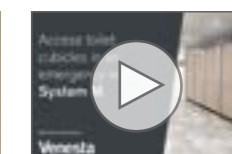
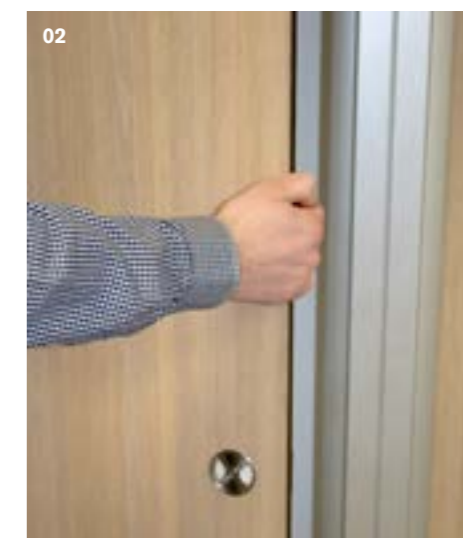

See System M cubicles in action by watching our dedicated video on our YouTube channel.

### Key features

- Award-winning, patented emergency access system
- Quick and easy access within an industry-leading 30 seconds
- Simple to release and reset, no damage to the cubicle
- No tools required for emergency release
- Complies with Document M, Document T, DDA and SSLD-3 Regulations
- Sleek floating appearance
- Attractive satin anodised aluminium pilasters and headrail
- 34 on-trend laminate finishes to choose from

## System M

System M features an innovative pivoting pilaster design with a discreet release facility operated without the use of tools or removable parts, allowing the normally inward opening door to be opened outwards within an industry-leading 30 seconds.

Re-setting is simple, with no replacement parts and no visual compromise to the stylish design.

### System M functionality.

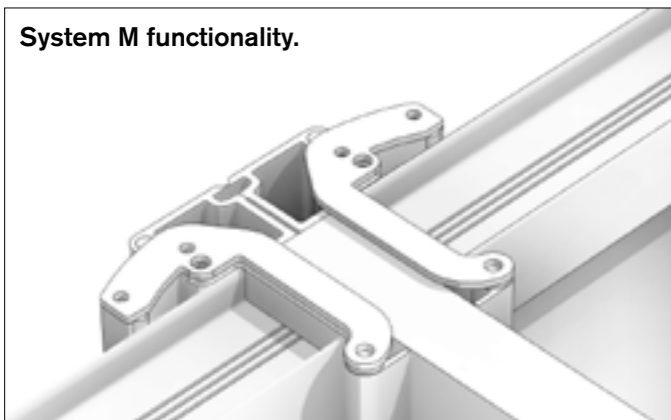

### Stage 1.



### Stage 2.

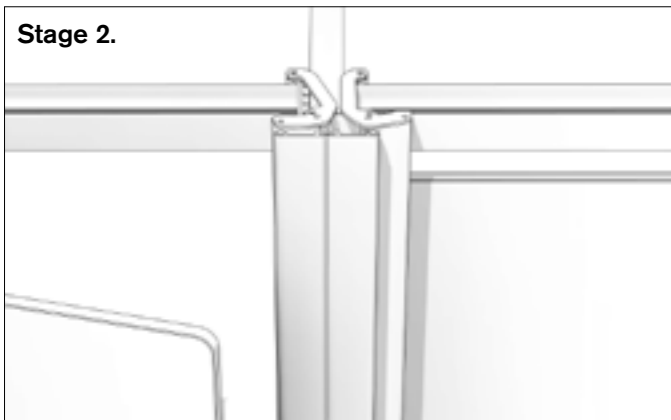

### Emergency release:

Stage 1: System M's innovative pivoting pilaster release system is not apparent to the everyday user and therefore retains a standard level of security and privacy.

Stage 2: In the event of an emergency, staff can open the lock using a coin, which allows the door to move freely. The pilaster can then be "squeezed" to release the door outwards, providing an emergency response time of less than 30 seconds.



**Main image**  
System M cubicles and  
WT1 profile vanity.

See p66-67 for  
System M technical  
specifications.

## Case Study London Gatwick Airport



London Gatwick is the second largest airport in the UK, flying to more destinations than any other UK airport. Gatwick has more than 280,000 flights across 90 airlines, carrying more than 46 million passengers per year.

Since 2009, Gatwick has undergone ongoing transformation to improve passenger experience through a £2.5 billion investment programme to all areas of the airport, including the washrooms.

With a requirement for a robust washroom to withstand the heavy footfall, System M was recommended for its durable and stylish design with its unique ability to access the cubicles in less than 30 seconds in an emergency.

The patented system enables normally inward opening doors to be opened outwards in an emergency, without having to break components or lift off pilasters or doors, the perfect solution for an airport.

At Venesta Washrooms, we understand that safety is paramount in busy airports. With our System M toilet cubicle range, Gatwick has peace of mind they are able to react quickly and easily in an emergency without damage to their washroom systems.

**Read the full case study at [www.venesta.co.uk](http://www.venesta.co.uk)**



## Case Study Derriford Hospital

**“We decided on the System M cubicle to aid with manual handling and to assist with a quick access should we need to.”**

Peter Caton, Senior Planning Support Manager & Site Service at Derriford Hospital.

Derriford Hospital forms part of the University Hospitals Plymouth NHS Trust and is the largest hospital in the south west peninsula, providing access to comprehensive secondary and tertiary healthcare for almost 2,000,000 people.

To complement the opening of their new, state-of-the-art Changing Places facility, that will greatly improve the experience of disabled patients and their families, the hospital realised a need to improve the reception foyer washrooms.

With safety a priority for all healthcare facilities around the world, we were asked to design a bespoke cubicle system to meet the specific needs of Derriford Hospital. Above all, the washrooms would need to accommodate a high footfall of patients and visitors of all abilities.

As well as allowing rapid access, the washrooms also needed to be strong and durable to support the challenging environment of a major hospital. System M made the ideal choice and was tailored to suit the needs of the environment with doors and partitions manufactured from our strongest material, Solid Grade Laminate; defending against scratches, water and moisture, vandalism and hard impact.

“The overall reaction from users has been that they are delighted with the new facilities, commenting on the extra space, increased number of cubicles, simple but useful accessories such as bag hooks and the colour of the cubicles.”

**Read the full case study at [www.venesta.co.uk](http://www.venesta.co.uk)**



# Technical Specifying System M

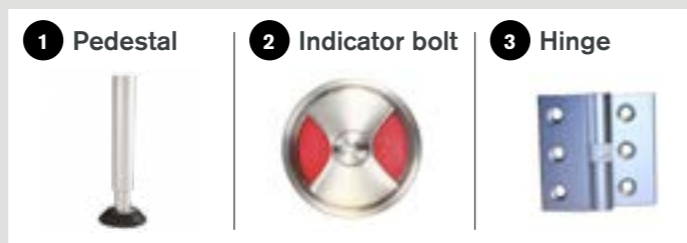
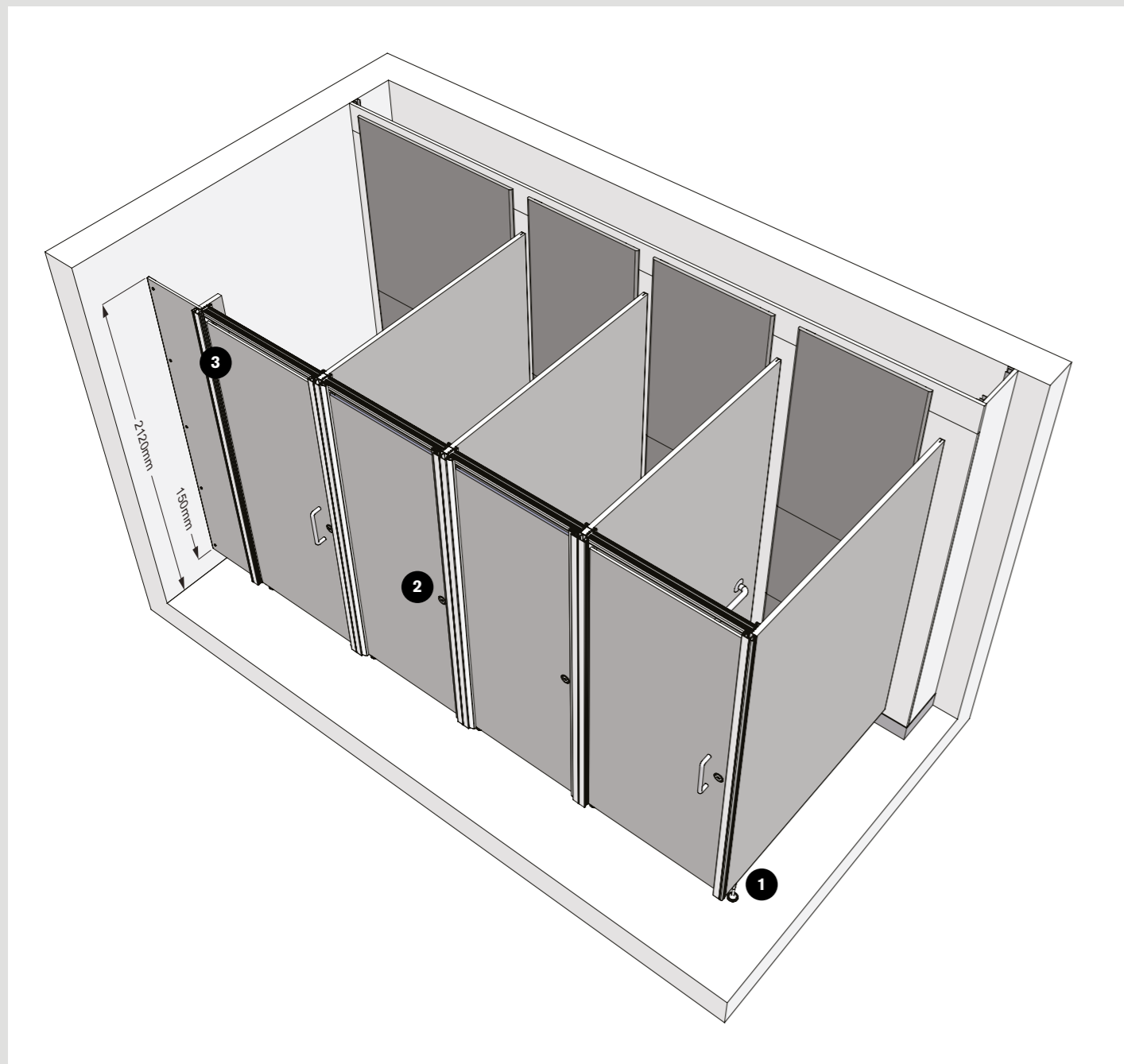

## Dimensions

**Standard height**  
2120mm

**Maximum depth**  
2068mm

**Floor clearance**  
150mm

**Minimum ceiling clearance**  
100mm

## Performance

System M cubicle partitions are manufactured in 26mm medium density fibreboard (MDF) faced both sides with High Pressure Laminate (HPL) and edges with matching lipping.

Doors are manufactured in 13mm Solid Grade Laminate (SGL) with radiused edges.

### HPL

For more heavily used washrooms, panels are heat, scratch and impact resistant.

### SGL

Solid Grade Laminate is extremely resistant to impact and all surfaces are impervious to water.

## Detailing

**Panels and doors**  
HPL panels and SGL doors.

**Colour finish**  
**HPL and SGL**  
34 colours from the standard range.  
**Cubicle hardware**  
Stainless steel and satin anodised aluminium.

### Edge treatment

**HPL**  
Matching lipping.  
**SGL**  
Polished black radiused edge.

### Headrail

High strength satin anodised aluminium U-section headrail.

### Pilasters

Unique, patented, pivoting high strength satin anodised aluminium shaped pilaster fixed to cubicle partition. Pilasters allow doors to open outwards in an emergency.

### Cubicle hardware

**Indicator bolt**  
Stainless steel circular faced indicator bolt with emergency release and nylon keep.

### Hinge

Satin anodised aluminium anti-tamper lift off rise and fall hinge.

### Pedestal

150mm stainless steel height adjustable pedestal.

### Fixings

Partition to wall: Satin anodised aluminium T-section.

### Accessories

Coat hooks and toilet roll holders available.

**Centurion stands for strength and rigidity but because we believe even the toughest of washrooms deserve some style, it looks good too. Satisfying your need for extra privacy, the range comes with standard, full-height or increased privacy options.**



## Centurion

Centurion's strength comes from a number of key details. Wall channels offer extra rigidity and pilasters extend to the floor, so no pedestals are required. Easy to clean, robust and vandal-proof, these cubicles come with hardwearing fittings.

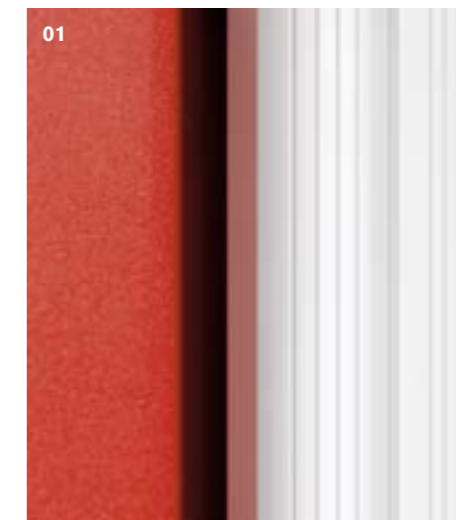

**01** High strength, fluted satin anodised aluminium pilaster.

**02** Indicator bolts come with emergency release facility as standard.

See p76-77 for Centurion technical specifications.

**Main image**  
Centurion HPL with satin anodised aluminium pilasters and Vepps HPL panels.

### Key features

- Robust frame design
- Fluted satin anodised aluminium pilasters
- Renowned for strength and rigidity
- Hardwearing and easy to maintain
- Easily adjustable hinges
- Emergency release indicator bolts
- A choice of 34 on-trend laminates

## Centurion Full Height

A handsome design in any setting, Centurion Full Height cubicles are supplied with floor to ceiling toilet partitions and overpanels above the doors, creating a private space. So if you're looking for extra privacy when specifying cubicles, Centurion Full Height will satisfy your needs.



**01** Floor fixed satin anodised aluminium pilasters with 5mm floor clearance.

**02** Fluted satin anodised aluminium pilaster and overpanels above doors.

See p76-77 for Centurion Full Height technical specifications.

### Main image

Centurion Full Height SGL cubicles with satin anodised aluminium pilasters.



### Key features

- Robust frame design
- Fluted satin anodised aluminium pilasters for added strength
- Overpanels above doors with full-height partitions offers privacy for users
- Easily adjustable hinges
- Floor to ceiling for increased privacy
- Emergency release indicator bolts

# Case Study Tudor Grange Academy

**“To meet the rigorous demands of this type of environment, all facilities in our academy have to be robust, efficient and fit for purpose. Centurion has fulfilled these requirements, and has given an excellent finished appearance.”**

Graham Turner, Facilities Manager at Tudor Grange Academy.

Rated 'Outstanding' by Ofsted, Tudor Grange Academy is a comprehensive school in South Solihull. Also awarded 'World Class School' status, Tudor Grange is committed to delivering a high-quality educational experience for its 1,600 students.

The Academy strives to create a safe and secure space for its students and staff, giving everyone the opportunity to achieve and succeed. They wanted to make the new school washrooms a more open and less intimidating space for all students. The washrooms would also need to be easy for staff to supervise, where needed.

Tudor Grange Academy had a requirement for robust, high specification toilet cubicles that would be able to withstand the rigours of a large and busy Academy; as well as a panelling system that would be easy to maintain.

Renowned for strength and rigidity, Solihull Council chose the Centurion Full Height toilet cubicle range for six male and female unisex school toilets around the campus.

Robust Centurion Full Height cubicles specified in dark grey laminate, along with pre-plumbed Vepps panelling in yellow and green help create a positive, bright and airy unisex washroom environment. Combine that with the hardwearing materials chosen, Tudor Grange Academy's washrooms could withstand even the most boisterous teenage antics.

**Read the full case study at [www.venesta.co.uk](http://www.venesta.co.uk)**



# Technical Specifying Centurion

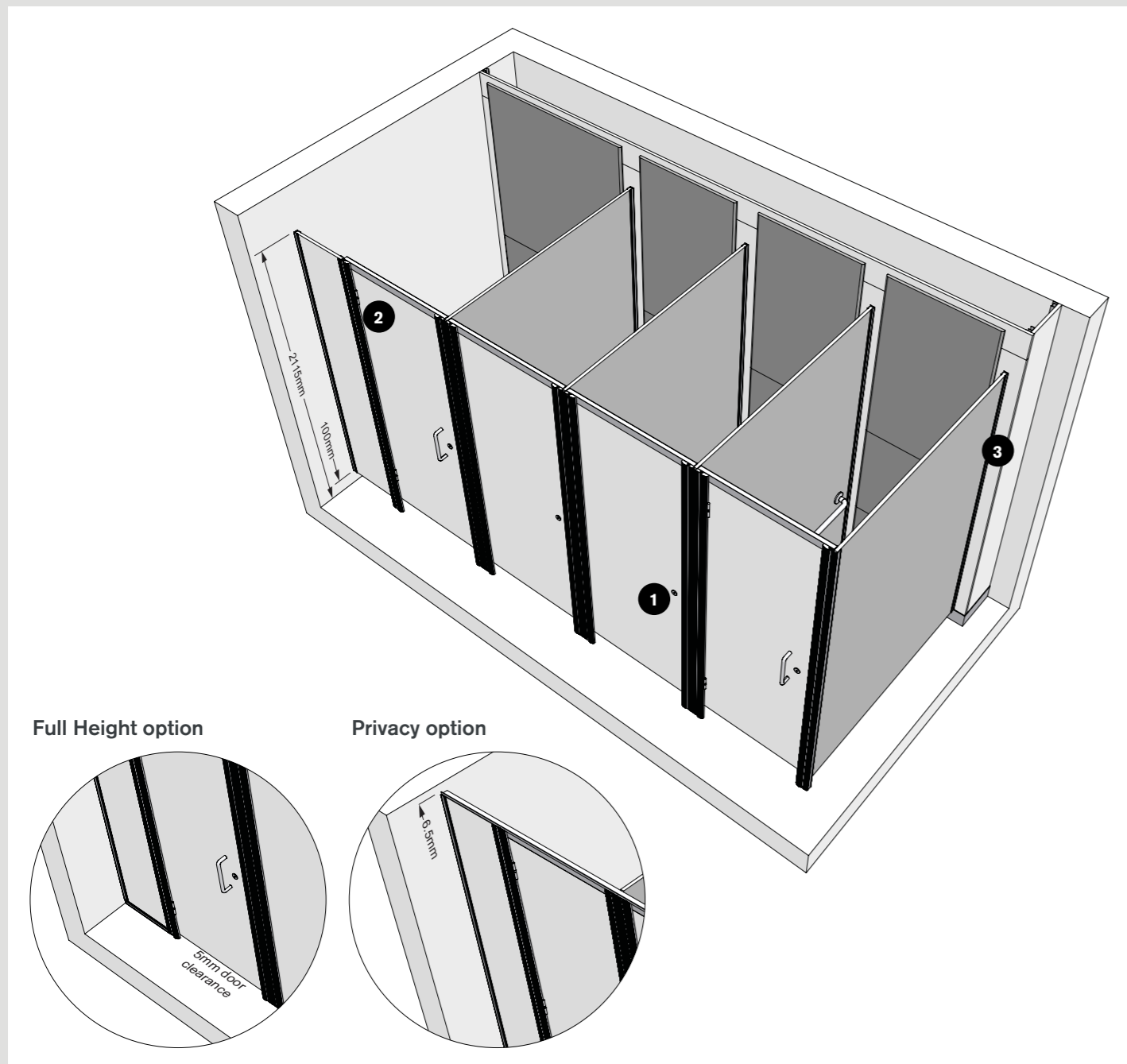

Full Height option

Privacy option



## Dimensions

<b>Centurion</b>	
<b>Overall height</b>	2115mm
<b>Maximum depth</b>	
MFC	2092mm
HPL	2062mm
SGL	1922mm
<b>Floor clearance</b>	100mm
<b>Minimum ceiling clearance</b>	20mm
<b>Centurion Full Height</b>	
<b>Maximum height</b>	
MFC	2774mm
HPL	2774mm
SGL	2774mm
<b>Maximum depth</b>	
MFC	2040mm
HPL	2040mm
SGL	1922mm
<b>Floor clearance</b>	5mm at doors 0mm at partitions and pilasters
<b>Minimum ceiling clearance</b>	20mm
<b>Centurion Privacy</b>	
<b>Maximum height</b>	
MFC	2816mm
HPL	2816mm
SGL	2816mm
<b>Maximum depth</b>	
MFC	2040mm
HPL	2040mm
SGL	1922mm
<b>Floor clearance</b>	5mm at doors 0mm at partitions and pilasters
<b>Minimum ceiling clearance</b>	6.5mm

## Performance

Available in three material options, Centurion is suitable for every type of wet or dry environment, allowing you to specify the most appropriate option to meet the site requirements and your budget.

**MFC**  
For dry environments with low risk of vandalism. Panels are manufactured from 19mm nominal thickness high performance moisture-resistant Melamine Faced Chipboard. Edges with matching lipping.

**HPL**  
For more heavily used washrooms, panels are heat, scratch and impact resistant. Manufactured from moisture-resistant chipboard faced with High Pressure Laminate, panels are 19mm nominal thickness. Edges with matching lipping.

**SGL**  
Solid Grade Laminate is extremely resistant to impact and all surfaces are impervious to water. Panels are 13mm nominal thickness with polished black radiused edges.

## Detailing

**Panels and doors**  
Available in MFC, HPL and SGL.

**Colour finish**  
**MFC, HPL and SGL**  
34 colours from the standard range.  
**Cubicle hardware**  
Satin anodised aluminium and satin anodised effect powder coated zinc.

**Edge treatment**  
**MFC and HPL**  
Matching lipping.  
**SGL**  
Polished black radiused edge.

**Headrail**  
High strength extruded satin anodised aluminium headrail.

**Pilasters**  
High strength extruded fluted satin anodised aluminium pilasters which extend down to floor level and are fixed to floor using mounting blocks.

**Cubicle hardware**  
**Indicator bolt**  
Satin anodised aluminium slide operated bolt with circular face plate and emergency release facility. Faceplate and keep with concealed fixings.

**Hinge**  
Standard and Full Height: Anti-finger trap satin anodised effect powder coated zinc rise and fall hinge. Outward opening hinge option available.  
Privacy: Satin anodised effect powder coated zinc 5mm nominal door clearance rise and fall hinge. This is not an anti-finger trap hinge.

**Fixings**  
Partition to wall: Continuous satin anodised aluminium U-channel.  
Pilaster to partition: Continuous satin anodised aluminium U-channel.  
Pilaster to wall: Continuous satin anodised aluminium U-channel.  
Partition to floor: Continuous satin anodised aluminium floor U-channel (for Full Height and Privacy only).

**Accessories**  
Coat hooks and toilet roll holders available.

# V3

**We know cubicles.**  
V3 promises you cutting-edge design, refined aesthetics and superb craftsmanship. Welcome to the very best in prestigious, contemporary washrooms, guaranteed to exceed all your expectations.

**Outstanding designs that deliver on every level.**  
 Sleek and sophisticated with a host of clever details, V3 is our premium range of washrooms. We've used the latest technology and a range of exquisite materials to create a collection of contemporary excellence.

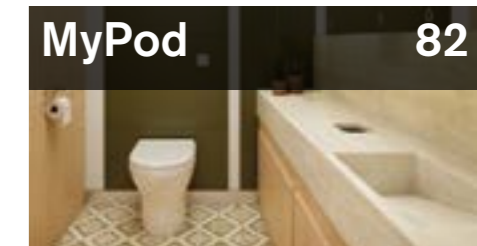
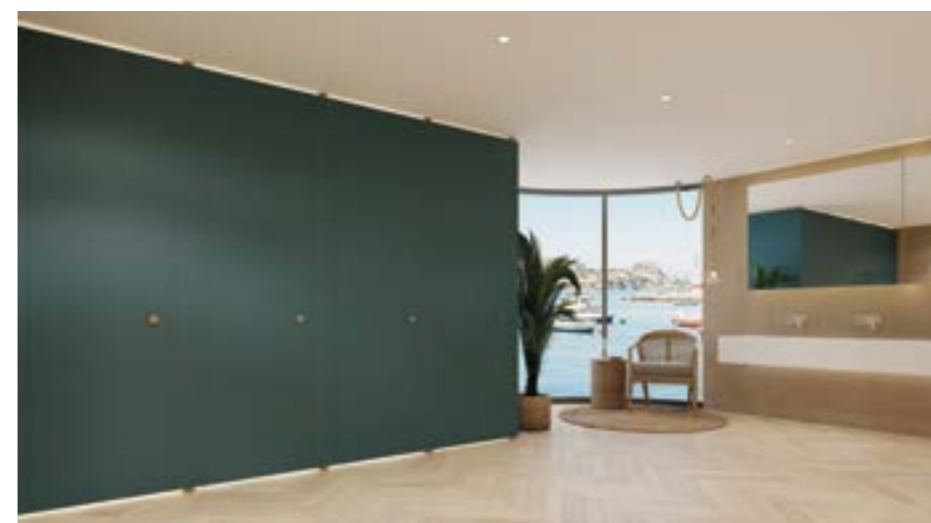

**MyPod 82**



**Infinite 92**



**Infinite Full Height with Headrail 96**



**Infinite Full Height with Fixing Blocks 98**

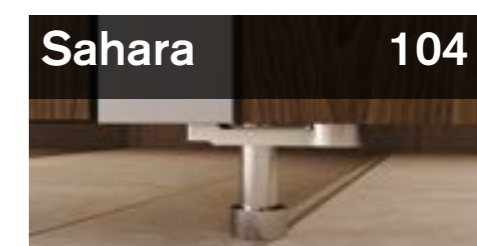

**Sahara 104**



**Sahara Glass 110**



V3

**MyPod combines luxury with innovation to deliver exquisite craftsmanship and timeless sophistication while ensuring maximum privacy for users.**

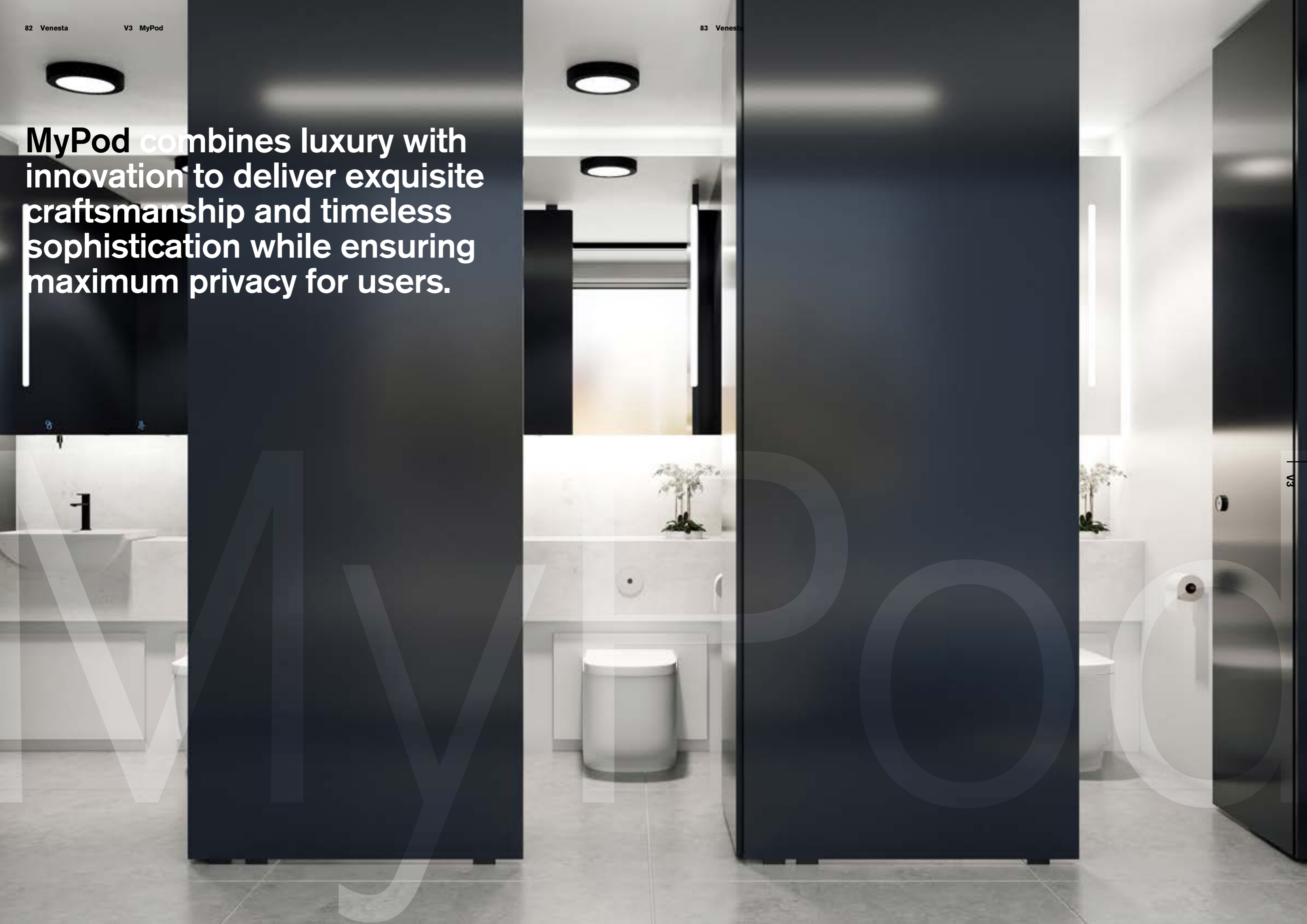

## MyPod

MyPod is the latest washroom concept that offers a single occupancy design, encapsulating all necessary amenities into one washroom system. Suitable for standalone rooms and cubicle settings, MyPod ensures maximum privacy for users. Specify MyPod in 4 premium finishes, including HPL, ColourCoat, ColourCoat High Gloss and ethically sourced real wood veneers for ultimate design flexibility.



**01** Eliminate the need for communal handwashing and drying areas.

**02** Strong and secure floor and ceiling fixing blocks for maximum privacy.

### Main image

MyPod ColourCoat cubicle in Mid Grey with black effect fittings. 1300mm MyPod Mirror Box Unit with Solid Surface H2 vanity in Crystal, Light Grey ColourCoat underpanels and Hartley basin mixer taps in matt black.



### Key features

Choose from fully integrated sanitaryware, MyPod panelling, vanity units and concealed Mirror Box Units

Compact washroom solution for space restricted areas

Single occupancy concept prioritises safety and inclusivity for users

Eliminate the need for communal handwashing facilities for improved washroom hygiene

Self-closing hinges for a minimal look with clean lines

Specify stainless steel and aluminium fittings in our standard, black, brass or bronze effect finishes

Sleek and secure cubicle fixtures for added durability





#### Key features

- Bespoke superloo design for various washroom configurations
- Adaptable to be used in a self-contained room
- Specify fully integrated sanitaryware, Vepps panelling, vanity units and concealed Mirror Box Units
- Maximise available washroom space by specifying facilities in a standalone unit
- Available to specify in HPL, ColourCoat, ColourCoat High Gloss and real wood veneer for endless design options

## MyPod

The integrated superloo design maximises washroom space while providing privacy and inclusivity, the ideal solution for gender neutral washrooms. Adaptable to be used in self-contained rooms, MyPod features fully integrated sanitaryware, panelling, vanity units and Mirror Box Units with concealed accessories.



01

**01** MyPod's compact design maximises washroom space.

**02** Self-contained washroom concept for optimum privacy.

See p90-91 for MyPod technical specifications.

#### Main image

MyPod panelling in Olive and Porcelain. 1300mm MyPod Mirror Box Unit with a MyPod Washtrough in Travertine and Soft Oak underpanels.

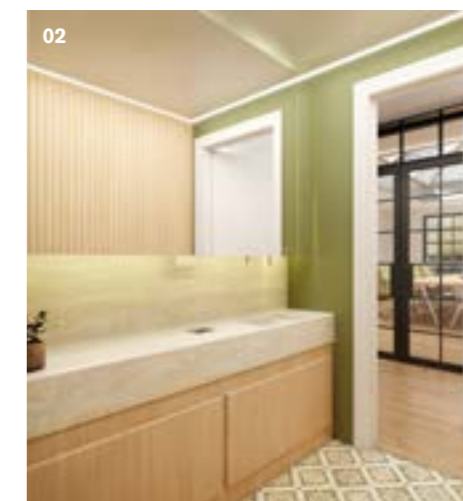

02

# MyPod

MyPod can be specified with full-height cubicles set into strong and secure floor and ceiling fixing blocks for maximum user privacy and durability. For a luxurious design, self-closing hinges provide a minimal and sleek look when cubicles are vacant. Further elevate the aesthetic of each superloo with stylish stainless steel and aluminium fittings in our standard, black, brass or bronze effect finishes for flexible colour and design combinations.

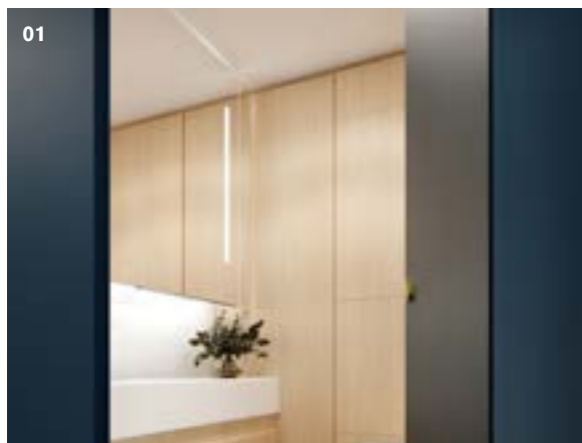

**01** Self-closing hinges provide a sleek look when cubicles are vacant.

**02** MyPod Mirror Box Unit lighting allows limitless colour combinations.

See p90-91 for MyPod technical specifications.

## Main image

MyPod cubicles with floor and ceiling fixing blocks in Indigo with brass effect fittings. MyPod washtrough in Limestone and Soft Oak with Aquarius deck mounted A45 sensor taps in chrome.

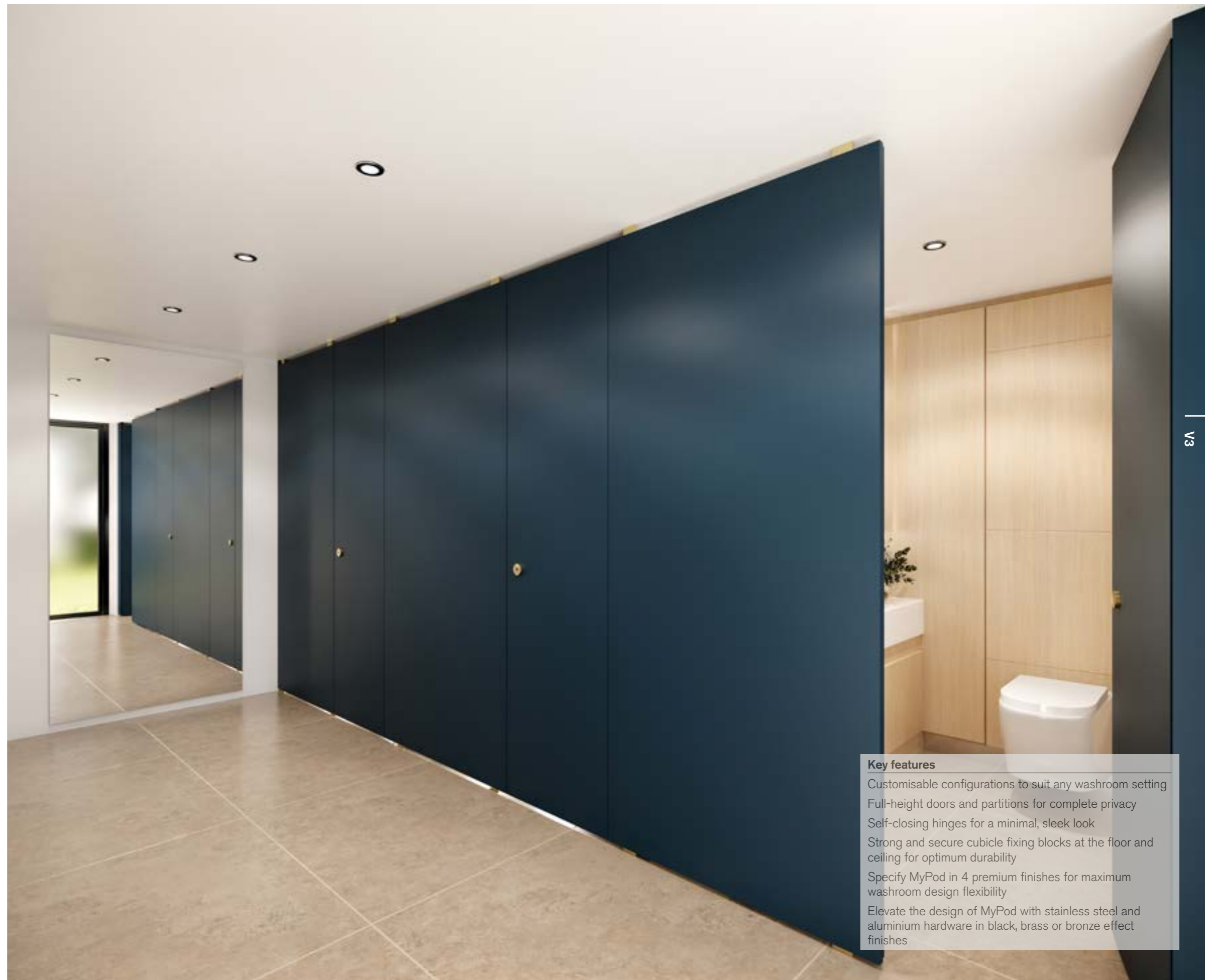

## Key features

- Customisable configurations to suit any washroom setting
- Full-height doors and partitions for complete privacy
- Self-closing hinges for a minimal, sleek look
- Strong and secure cubicle fixing blocks at the floor and ceiling for optimum durability
- Specify MyPod in 4 premium finishes for maximum washroom design flexibility
- Elevate the design of MyPod with stainless steel and aluminium hardware in black, brass or bronze effect finishes

# Technical Specifying MyPod

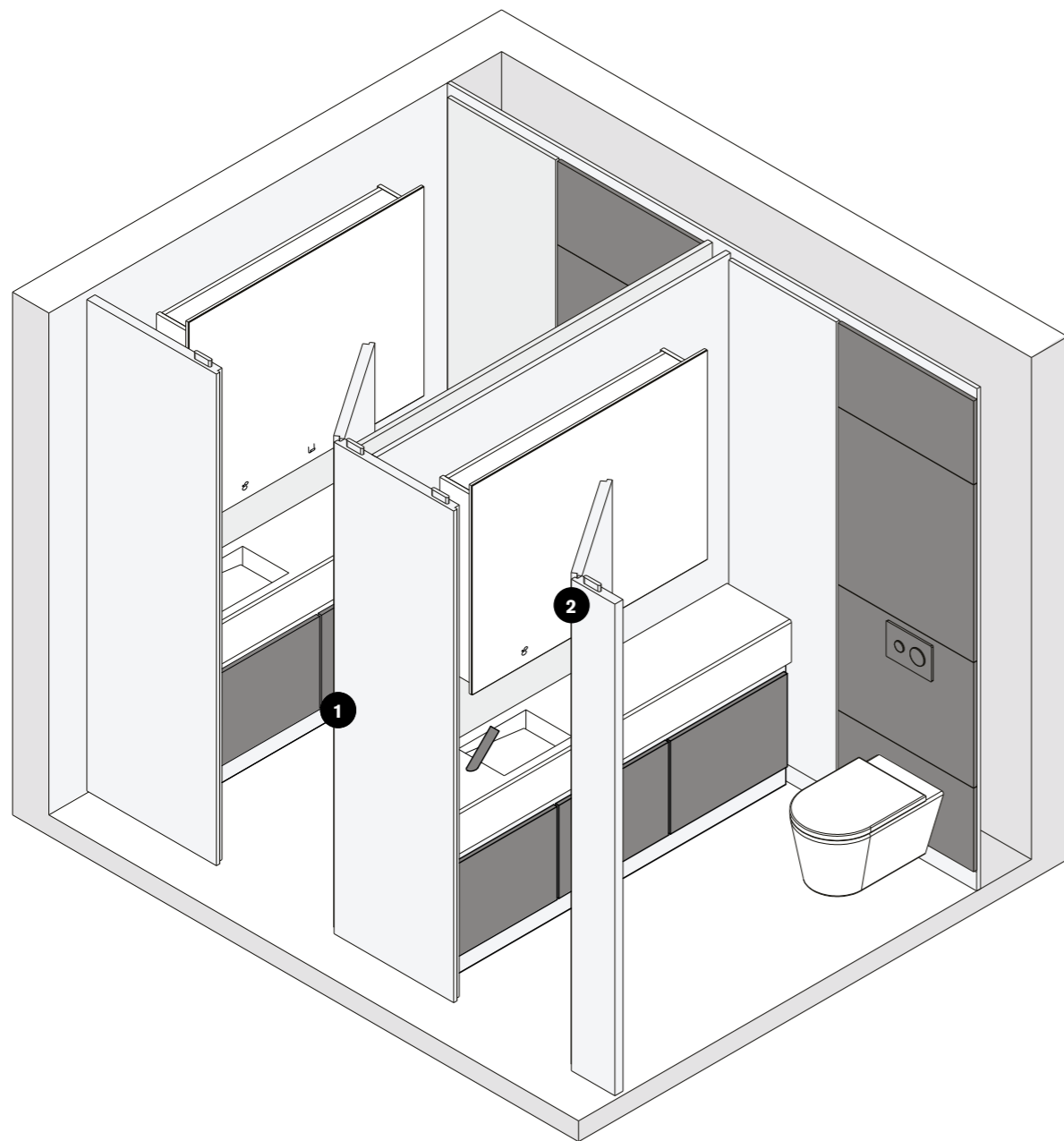

**1** Indicator bolt    **2** Fixing Block



## Dimensions

### MyPod cubicles

#### Overall height

HPL	2815mm
ColourCoat	2815mm
ColourCoat High Gloss	2815mm
Veneer	2815mm

#### Maximum depth

HPL	2090mm
ColourCoat	2090mm
ColourCoat High Gloss	2090mm
Veneer	2090mm

#### Floor clearance

20mm to cubicle fronts.  
Partitions taken to the floor in a privacy channel.

#### Minimum ceiling clearance

30mm above doors.  
Partitions taken to the ceiling in a privacy channel.

### MyPod Panelling

#### Maximum ceiling height

3000mm  
Maximum heights subject to change with woodgrain colours. Bespoke heights available.

#### Skirting/baseraill height

100mm

#### Top flashgap

50mm

#### Hinged panels

Hinged and lockable panels available up to 850mm width.

MyPod panelling is available in Vepps, Rapiduct and Frameduct.

### MyPod Mirror Box Units

#### Height

1000mm

#### Width

Bespoke. Available in 5mm increments from 500mm up to 1300mm maximum.

#### Depth

210mm

### MyPod Solid Surface Washtrough

#### Maximum Length

Depth: 355mm  
Downstand: 200mm  
Length: Bespoke. 3000mm maximum single trough.

### MyPod Combi Unit

#### Maximum Length

Depth: 350mm  
Downstand: 300mm  
Length: Bespoke. 2770mm maximum single unit.

## Performance

Available in four material options, MyPod is suitable for even the most prestigious environments allowing you to specify with confidence.

### HPL

Doors and pilasters are 45mm nominal thickness with an MDF core, partitions are 26mm nominal thickness.

### ColourCoat

Doors and pilasters are 44mm nominal thickness MDF, partitions are 25mm MDF, both are sprayed with a coat of primer and finished with 20% gloss pigmented lacquer.

### ColourCoat High Gloss

Doors and pilasters are 44mm nominal thickness MDF, partitions are 25mm MDF, both are sprayed with a coat of primer and finished with 80% gloss pigmented lacquer.

### Veneer

Doors and pilasters are 45mm nominal thickness MDF faced with real wood veneer, partitions are 26mm MDF core faced with real wood veneer. Door, pilaster and partition edging in matching lipping from the Venesta standard colour range.

## Detailing

### Panels and doors

Available in HPL, ColourCoat, ColourCoat High Gloss and Veneer.

### Colour finish

#### HPL

34 colours from the standard range.  
ColourCoat and ColourCoat High Gloss  
Any RAL classic colour, excluding metallic and fluorescent colours.

#### Veneer

11 Alpi real wood veneers (varying price points).  
Cubicle hardware  
Stainless steel and aluminium. Optional choice of black, brass or bronze effect coatings.

### Edge treatment

#### HPL

Matching lipping.

#### ColourCoat

Edges are sprayed with one coat of primer and finished with 20% gloss pigmented polyurethane lacquer.

#### ColourCoat High Gloss

Edges are sprayed with one coat of primer and finished with 80% gloss pigmented polyurethane lacquer.

#### Veneer

Matching lipping.

### Cubicle hardware

#### Indicator bolt

Stainless steel aluminium hinge (lift off available).  
Optional choice of black, brass or bronze effect coatings.

#### Hinge

Stainless steel aluminium hinge (lift off available).  
Optional choice of black, brass or bronze effect coatings.

#### Fixing Blocks

Stainless steel aluminium fixing blocks to floor and ceiling. Optional choice of black, brass or bronze effect coatings.

#### Fixings

Partition to wall: Satin anodised aluminium H-channel and Z-clips.

Pilaster to partition: Steel Z-clips.

Pilaster to wall: Satin anodised aluminium H-channel and Z-clips.

All fixings listed above have optional choice of black, brass or bronze effect coatings.

### Accessories

Coat hooks and toilet roll holders available. Optional choice of black, brass or bronze effect coatings.

**Infinite** is the ultimate in classic modernity, delivering sleek, clean lines, flush fronts and minimalist fittings. This is a contemporary, high quality solution, perfect for the most stylish environments.

infinite



**Key features**

- A choice of 4 finishes including 11 real wood veneers, for the most stylish washrooms
- Floating, flush fronted design
- Emergency release mortice lock indicator bolts
- Self-closing hinges for a minimal look with clean lines
- Sleek and strong stainless steel and aluminium fittings
- Optional choice of black, brass or bronze effect cubicle hardware for ultimate design flexibility

## Infinite

The ultimate in classic modernity, Infinite gives a better impression where it is keenly noticed. Floating fronts, adjustable stainless steel pedestals and a unique 3-part aluminium headrail system gives a flush-fronted, endless cubicle finish that's perfect for the most stylish environments.

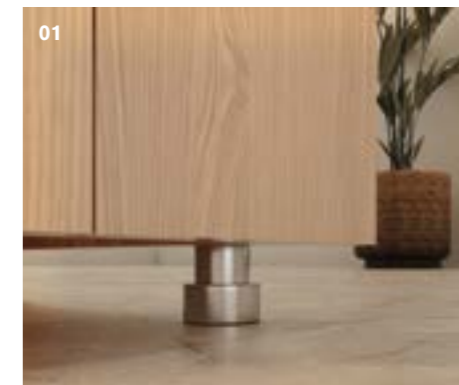

01

**01** Adjustable stainless steel pedestals are set back on partitions to give floating appearance.

**02** Indicator bolt with emergency release facility.

**03** Standard fittings.

**04** Black effect fittings.

**05** Brass effect fittings.

**06** Bronze effect fittings.

See p102-103 for Infinite technical specifications.

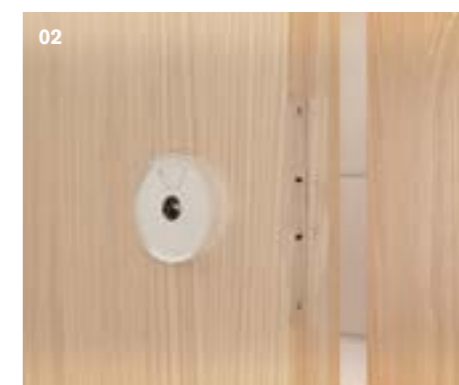

02

**Main image**

Infinite cubicles in American White Oak Straight Grain real wood veneer with Quartz Q4 profile vanity units in Nougat.



03



04

For the full choice of veneers, please visit [www.venesta.co.uk](http://www.venesta.co.uk), call our sales team on 01474 353333 or refer to our separate Colour Selector brochure.



05



06

## Infinite Full Height with Headrail

Our premium Infinite Full Height with Headrail range boasts all the same innovative features of Infinite, but with the added benefit of a full-height design. With minimal ceiling and floor clearances and rebate edge doors, this range offers unrivalled end user privacy. For added design flexibility in premium washroom settings, you have the choice of specifying the pedestals, headrails, indicator bolts, hinges and cubicle accessories in 4 finishes, including stainless steel, black, brass and bronze effect finishes.



**01** Sleek unique 3-part aluminium headrail system in brass effect finish.

**02** Adjustable stainless steel pedestal in brass effect finish, set back on partition to give floating appearance.

See p102-103 for Infinite Full Height technical specifications.

### Main image

Infinite Full Height with Headrail HPL cubicles in Dark Walnut with brass effect fittings. WT1 profile Solid Surface washtrough in Sunstone with Suede underpanels and Hartley basin mixer taps in brushed nickel.



02

### Key features

- A unique 3-part aluminium headrail system
- Adjustable stainless steel pedestals set back on partitions for a minimal, floating design
- Specify in a choice of 4 high grade, tried and tested finishes including real wood veneer
- Sleek stainless steel and aluminium fittings
- Self-closing hinges for a minimal look with clean lines
- Emergency release mortice lock indicator bolts
- Optional choice of black, brass or bronze effect cubicle hardware for design flexibility
- Choose any RAL Classic colour when specifying ColourCoat or ColourCoat High Gloss



## Infinite Full Height with Fixing Blocks

Infinite Full Height with Fixing Block cubicles boast an array of premium, innovative features, including our most secure emergency release indicator bolt to date. Sleek and strong ceiling and floor fixing blocks create a full floor-to-ceiling, flush-fronted, endless cubicle finish with maximum end user privacy guaranteed. Available in four high grade finishes, Infinite Full Height with Fixing Blocks gives you endless design possibilities.



**01** Brass effect mortice lock indicator bolt with emergency release mechanism.

**02** Brass effect floor fixing block for cubicle rigidity.

See p102-103 for Infinite Full Height technical specifications.

### Main image

Infinite Full Height with Fixing Block cubicles in Teal with brass effect fittings. Solid Surface WT2 profile washtrough in Everest with Hartley wall mounted mixer taps in brushed nickel and 1300mm Mirror Box Units.



### Key features

- Minimal flush fronted design
- Ceiling and floor fixing blocks for full-height cubicle
- Minimal floor and ceiling clearances for user privacy
- A choice of 4 finishes including 11 real wood veneers, for the most stylish washrooms
- Sleek stainless steel and aluminium fittings
- Our most secure emergency release indicator bolt to date
- Optional choice of black, brass or bronze effect cubicle hardware for ultimate design flexibility

## Case Study Sharjah Central Shopping Mall

### Infinite Full Height with Fixing Blocks has delivered ultra-modern and sleek washroom facilities to Sharjah Central Shopping Mall in United Arab Emirates.

Sharjah Central is a newly developed two storey retail and leisure destination, offering an enriching shopping experience to the local community in Sharjah, UAE. Boasting a wide selection of shops, restaurants, a 10,000 square metre hypermarket and an extensive entertainment complex, Sharjah Central's mission is to be the ultimate leisure destination for families and entertainment seekers.

Being in close proximity to Sharjah International Airport and Sharjah University City, footfall was expected to be high and steady. With this in mind, Abu Dhabi based management company Lulu Group International required a premium cubicle system which would offer visitors privacy and could stand the test of time too.

Infinite Full Height toilet cubicles were specified in heat, scratch and impact resistant High Pressure Laminate (HPL), an ideal material for heavily used areas. The ultimate in classic modernity, Infinite Full Height delivers sleek, clean lines, flush-fronts and minimalist fittings. 'Cloud' and 'Gunmetal' were the colours of choice for the cubicles, complementing the décor of the modern washrooms.

The cubicle partitions and pilasters are fixed to the floor and ceiling with fixing blocks for style and rigidity in equal measure. Meanwhile, the ceiling to floor cubicles and 20mm door clearances guarantee total user privacy.

The Infinite range boasts sleek stainless steel lever operated indicator bolts that offer quick emergency release from outside of locked cubicles. This means no damage is done to the cubicles or locks in the event of an emergency, which is a key consideration when specifying commercial washrooms in busy settings.

Read the full case study at [www.venesta.co.uk](http://www.venesta.co.uk)

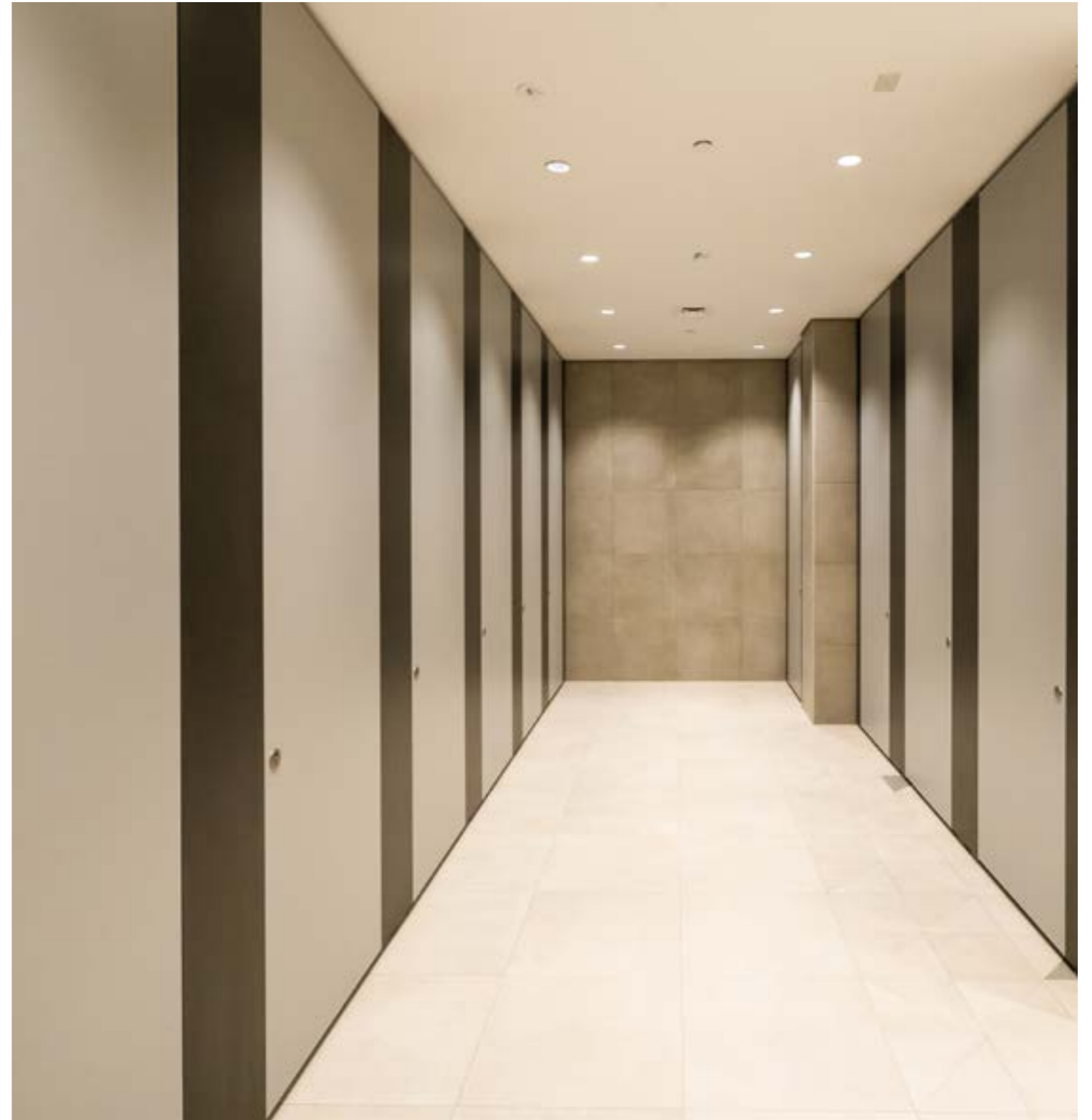

# Technical Specifying Infinite

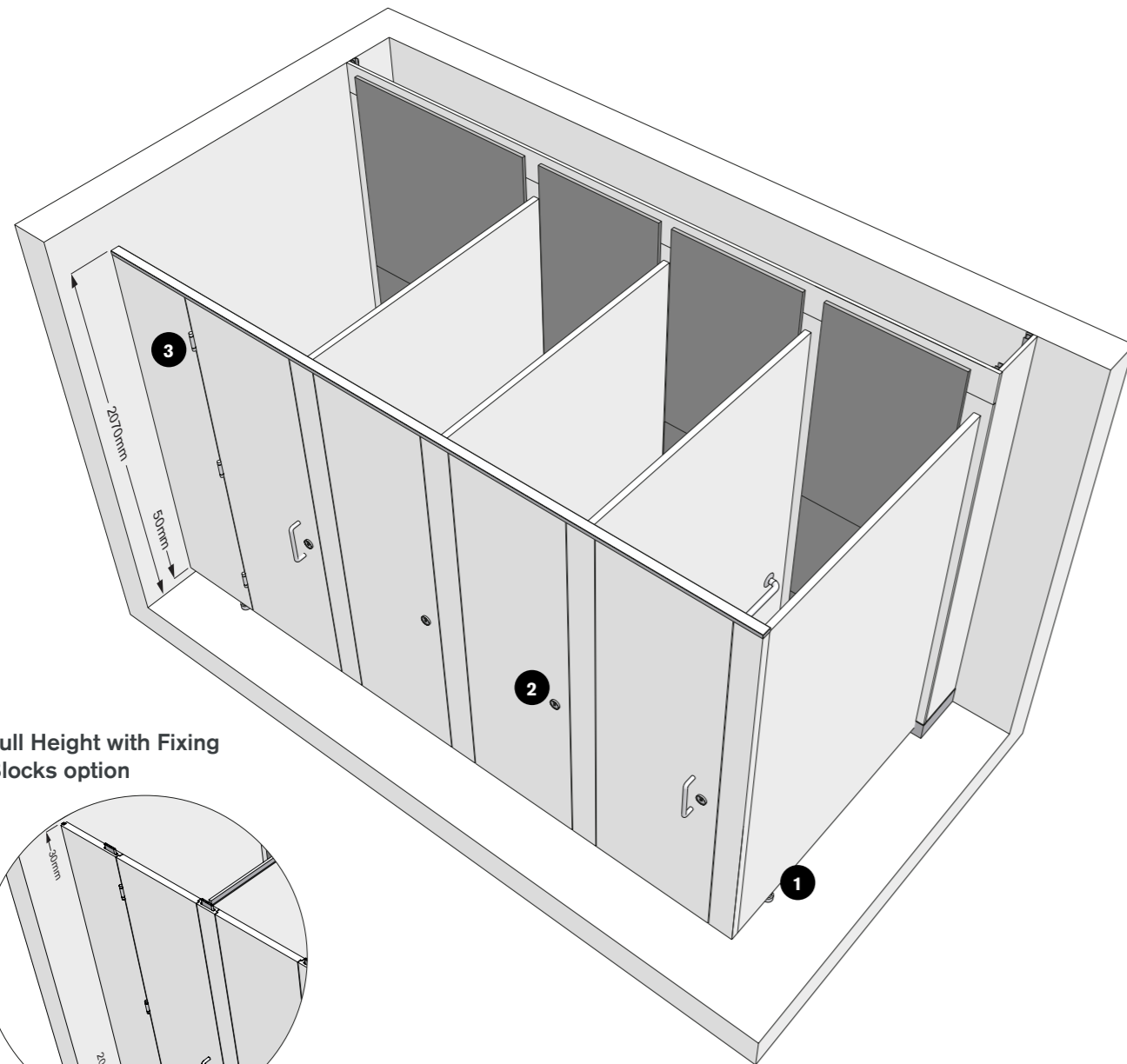

Full Height with Fixing Blocks option

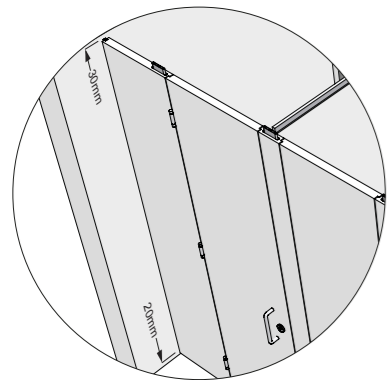

## Dimensions

### Infinite

**Overall height**  
2070mm

**Maximum depth**  
2090mm

**Floor clearance**  
50mm

**Minimum ceiling clearance**  
20mm

**Infinite Full Height with Headrail**  
**Maximum height**  
2830mm

**Maximum depth**  
2090mm

**Floor clearance**  
50mm

**Minimum ceiling clearance**  
20mm

**Infinite Full Height with Fixing Blocks**  
**Maximum ceiling height**  
2815mm

**Maximum depth**  
2090mm

**Floor clearance**  
20mm to cubicle fronts.  
Partitions taken to the floor in a privacy channel.

**Minimum ceiling clearance**  
30mm

## Performance

Available in four material options, Infinite is suitable for even the most prestigious environments allowing you to specify with confidence.

### HPL

Doors and pilasters are 44mm nominal thickness with an MDF core, partitions are 26mm nominal thickness.

### ColourCoat

Doors and pilasters are 45mm nominal thickness MDF, partitions are 25mm MDF, both are sprayed with a coat of primer and finished with 20% gloss pigmented lacquer.

### ColourCoat High Gloss

Doors and pilasters are 45mm nominal thickness MDF, partitions are 25mm MDF, both are sprayed with a coat of primer and finished with 80% gloss pigmented lacquer.

### Veneer

Doors and pilasters are 44mm nominal thickness MDF faced with real wood veneer, partitions are 26mm MDF core faced with real wood veneer. Door, pilaster and partition edging in matching lipping from the Venesta standard colour range.

## Detailing

### Panels and doors

Available in HPL, ColourCoat, ColourCoat High Gloss and Veneer.

### Colour finish

#### HPL

34 colours from the standard range. ColourCoat and ColourCoat High Gloss Any RAL classic colour, excluding metallic and fluorescent colours.

#### Veneer

11 Alpi real wood veneers (varying price points). Cubicle hardware Stainless steel and aluminium. Optional choice of black, brass or bronze effect coatings.

### Edge treatment

#### HPL

Matching lipping.

#### ColourCoat

Edges are sprayed with one coat of primer and finished with 20% gloss pigmented polyurethane lacquer.

#### ColourCoat High Gloss

Edges are sprayed with one coat of primer and finished with 80% gloss pigmented polyurethane lacquer.

#### Veneer

Matching lipping.

### Headrail (Not applicable to Infinite Full Height with Headrail)

Slimline profile satin anodised aluminium headrail with 3 part fixing system allowing cubicles to finish 20mm below ceiling height. Stainless steel end cap.

### Cubicle hardware

#### Indicator bolt

Stainless steel indicator bolt with slimline mortice lock and unique emergency release function.

#### Hinge

Stainless steel effect aluminium hinge (lift off available).

#### Pedestal

Infinite and Infinite Full Height with Headrail: Adjustable stainless steel pedestal.

Infinite Full Height with Fixing Blocks: Stainless steel effect aluminium fixing blocks to floor and ceiling.

#### Fixings

Partition to wall: Satin anodised aluminium H-channel and Z-clips.

Pilaster to partition: Steel Z-clips.

Pilaster to wall: Satin anodised aluminium H-channel and Z-clips.

Floor and ceiling fixing: Stainless steel effect aluminium fixing blocks (Infinite Full Height only).

### Accessories

Coat hooks and toilet roll holders available. Optional choice of black, brass or bronze effect coatings.

**Sahara** Inspired by bold minimalism, our premium V3 cubicle range boasts an innovative pivot hinge system that's synonymous with opulent interior design and architecture.



sahara

# Sahara

Sahara promises to make an impact in premium washrooms thanks to the floating, flush fronts and sleek hardware. With discreet soft self-closing pivot hinges that offer smooth door movement, Sahara really is the epitome of prestigious washroom cubicle design.

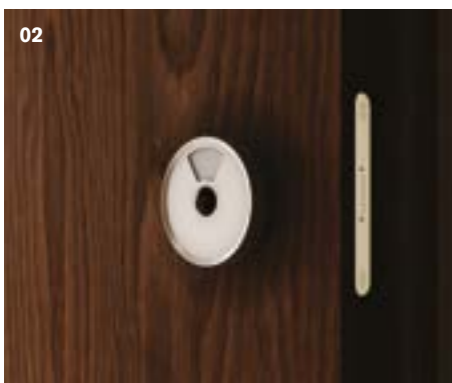

**01** Self-closing pivot hinges in stainless steel, with set back pedestals for floating effect.

**02** Indicator bolt with emergency release facility.

See p112-113 for Sahara technical specifications.

## Main image

Sahara cubicles in American Black Walnut crown cut real wood veneer.

For the full choice of veneers, please visit [www.venesta.co.uk](http://www.venesta.co.uk), call our sales team on 01474 353333 or refer to our separate Colour Selector brochure.



## Key features

- A choice of 11 luxurious real wood veneers
- Discreet soft self-closing pivot hinges
- Flush fronted design due to rebated doors
- Minimal look with clean lines and a floating appearance
- Sleek satin anodised aluminium and stainless steel fittings
- FSC certified veneers sourced from responsible and sustainable forests



#### Key features

- Hidden soft self-closing pivot hinges
- Flush fronted, floating appearance
- Slimline satin anodised aluminium pilasters and headrail
- Emergency release indicator bolts
- Minimal look and clean lines
- Choose any classic RAL colour
- Height adjustable pedestals

## Sahara

Unique to the Sahara range, the cubicle doors boast our innovative floating pivot hinge system which creates an elegant, smooth door movement. Specify Sahara in HPL, ColourCoat, ColourCoat High Gloss or real wood veneer to make a bold statement and create a modern design fit for illustrious washroom areas.



**01** Slimline satin anodised aluminium headrail and pilasters.



**02** Stainless steel indicator bolt with slimline mortice lock and unique emergency release function.

#### Main image

Sahara ColourCoat cubicles in Dark Grey (RAL7026). Solid Surface H2 profile vanity in Everest and Gunmetal, with Marden square semi-recessed basins and Hartley mixer taps in matt black.

See p112-113 for Sahara technical specifications.

#### ColourCoat

ColourCoat is our vibrant range of contemporary spray painted colours. Doors and partitions are sprayed with a coat of primer and finished with 20% gloss pigmented lacquer.

#### ColourCoat High Gloss

ColourCoat High Gloss is our highly reflective, spray painted colour finish. Doors and partitions are sprayed with a coat of primer and finished with 80% gloss pigmented lacquer.

Note: for V3 products, any colour from the RAL classic colour chart can be chosen, excluding metallic and fluorescent colours.

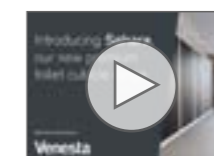

See Sahara cubicles in action by watching our dedicated video on our YouTube channel.

## Sahara Glass

With a slimline profile, flush fronted design and sleek hardware, Sahara Glass presents an undisputable premium look for the most prestigious commercial washroom areas. Specify either black or white 4mm toughened safety glass clad cubicles to create an effortless, timeless design.



**01** Stainless steel indicator bolt with mortice lock.



**02** Soft self-closing pivot hinged doors and set back pedestals for floating effect.

See p114-115 for Sahara Glass technical specifications.

### Main image

Sahara Glass cubicles in White. Quartz Q5 profile vanities in Frost with Langley oval vessel basins and Hartley mono vessel basin mixer taps in chrome.

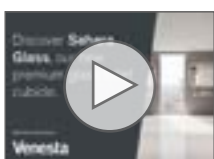

See Sahara Glass cubicles in more detail by watching our dedicated video on our YouTube channel.



### Key features

- Discreet soft self-closing pivot hinges
- Available in black or white 4mm toughened safety glass
- Pilasters clad in glass
- Slimline mortice lock indicator bolts with unique emergency release function
- Flush fronted with floating appearance

# Technical Specifying Sahara

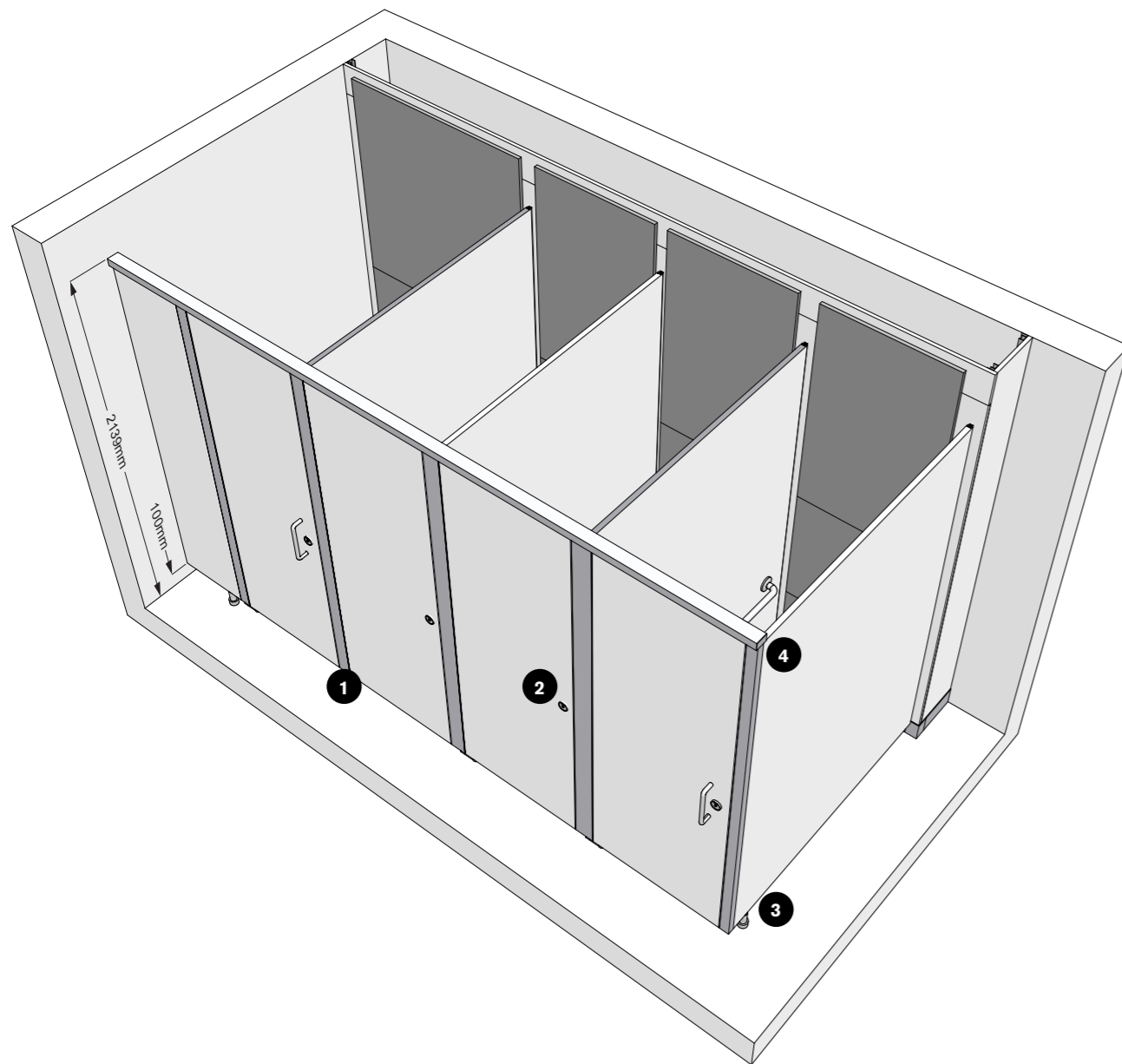

1 Pivot hinge



2 Indicator bolt



3 Pedestal



4 Headrail cap



## Dimensions

<b>Overall height</b>	
HPL	2139mm
ColourCoat	2139mm
ColourCoat High Gloss	2139mm
Veneer	2139mm
<b>Maximum height</b>	
HPL	2909mm
ColourCoat	2909mm
ColourCoat High Gloss	2909mm
Veneer	2909mm
<b>Maximum depth</b>	
HPL	2086mm
ColourCoat	2086mm
ColourCoat High Gloss	2086mm
Veneer	2086mm
<b>Floor clearance</b>	
100mm as standard (also a choice of 20mm, 50mm or 150mm)	
<b>Minimum ceiling clearance</b>	
20mm	

## Performance

Available in four material options, Sahara is suitable for the most prestigious restroom environments allowing you to specify with complete confidence.

### HPL

Doors are 36mm nominal thickness and partitions are 26mm nominal thickness, both with an MDF core.

### ColourCoat

Doors are 35mm nominal thickness and partitions are 25mm nominal thickness, both with an MDF core. Sprayed with a coat of primer and finished with 20% gloss pigmented polyurethane lacquer.

### ColourCoat High Gloss

Doors are 35mm nominal thickness and partitions are 25mm nominal thickness, both with an MDF core. Sprayed with a coat of primer and finished with 80% gloss pigmented polyurethane lacquer.

### Veneer

Doors are 36mm nominal thickness chipboard faced with real wood veneer. Partitions are 26mm nominal thickness with an MDF core, faced with real wood veneer. Door and partition edges are lipped with matching melamine from the standard Venesta colour range.

## Detailing

### Panels and doors

Available in HPL, ColourCoat, ColourCoat High Gloss and Veneer.

### Colour finish

#### HPL

34 colours from the standard range.

**ColourCoat and ColourCoat High Gloss**  
Any RAL classic colour, excluding metallic and fluorescent colours.

#### Veneer

11 Alpi real wood veneers (varying price points).

#### Hardware

Satin anodised aluminium and stainless steel.

### Edge treatment

#### HPL

Matching lipping.

#### ColourCoat

Edges are sprayed with one coat of primer and finished with 20% gloss pigmented polyurethane lacquer.

#### ColourCoat High Gloss

Edges are sprayed with one coat of primer and finished with 80% gloss pigmented polyurethane lacquer.

#### Veneer

Matching edging from the standard range.

### Pilasters

High strength, slimline extruded satin anodised aluminium pilasters specially designed to conceal fixings.

### Headrail

40mm slimline satin anodised aluminium with matching end cap.

### Hardware

#### Indicator bolt

Stainless steel indicator bolt with slimline mortice lock and unique emergency release function.

#### Hinge

Stainless steel soft self-closing pilaster mounted pivot hinges, supplied as an assembly.

#### Pedestal

Stainless steel 100mm height adjustable (+10mm) as standard. Also a choice of 50mm or 150mm height pedestals.

#### Fixings

Partition to wall: Satin anodised aluminium Z-clip.

Pilaster to partition: Aluminium Z-clip.

Pilaster to wall: Satin anodised channel and Z-clip.

### Accessories

Coat hooks and toilet roll holders available.

# Technical Specifying Sahara Glass

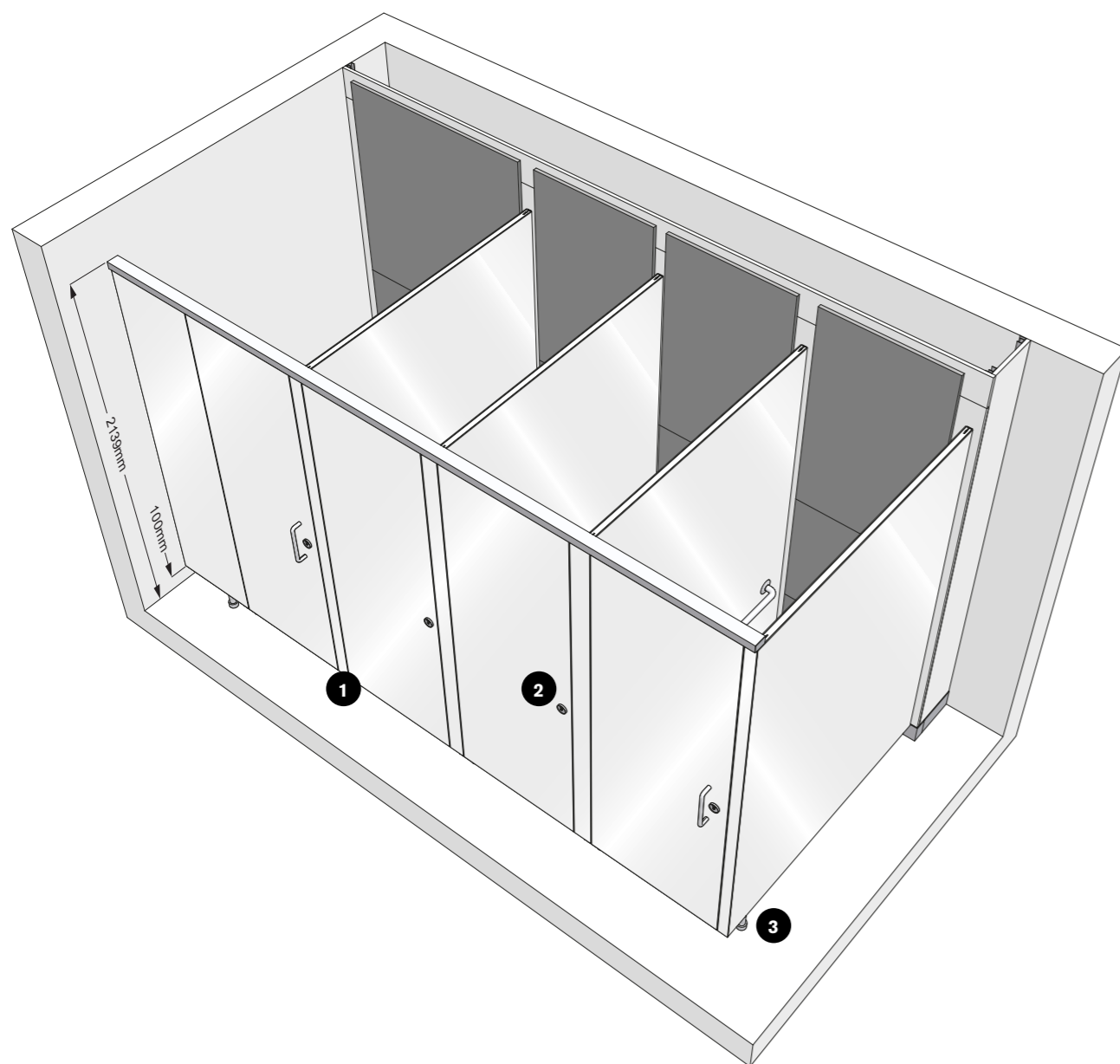

1 Pivot hinge



2 Indicator bolt



3 Pedestal



## Dimensions

### Overall height

2139mm

### Maximum height

2909mm

### Maximum depth

2086mm

### Floor clearance

100mm as standard (also a choice of 20mm, 50mm or 150mm)

### Minimum ceiling clearance

20mm

## Performance

### Glass

4mm toughened double back painted safety glass available in timeless black or white.

Doors are 44mm nominal thickness high performance Medium Density Fibreboard (MDF) clad with double back painted safety glass. Partitions are 35mm nominal thickness clad with double back painted safety glass.

## Detailing

### Panels and doors

High performance Medium Density Fibreboard core clad in 4mm toughened double back painted safety glass.

### Colour finish

#### Glass

Black or white.\*

#### Core

Noir or Porcelain.

#### Hardware

Satin anodised aluminium, stainless steel and powder coated aluminium. Optional choice of black, brass or bronze effect coatings.

\*Other colours available upon request.

### Edge treatment

#### Glass

Polished.

#### Core

Lipped with matching lipping.

### Pilasters

High strength, slimline extruded satin anodised aluminium pilasters clad in glass, specially designed to conceal fixings.

### Headrail

40mm slimline powder coated aluminium in black or white with matching end cap.

### Hardware

#### Indicator bolt

Stainless steel indicator bolt with slimline mortice lock and unique emergency release function.

#### Hinge

Stainless steel soft self-closing pilaster mounted pivot hinges, supplied as an assembly.

#### Pedestal

Stainless steel 100mm height adjustable (+10mm) as standard. Also a choice of 50mm or 150mm height pedestals.

#### Fixings

Partition to wall: Satin anodised aluminium T-section.

Pilaster to partition: Satin anodised aluminium T-section.

Pilaster to wall: Satin anodised aluminium channel and Z-clip.

### Accessories

Coat hooks supplied as standard.

**We know specialist ranges.** Whether it's a vandalism prone environment, or one with rigorous health and safety considerations, we can guide you through our range of innovative, fit for purpose solutions.

**Specialist**

## We know education.

For over 40 years, we've been the washroom specialist of choice for countless nurseries, schools, colleges and universities. We know that performance, practicality and cost-effectiveness are your key considerations. They're ours too.



# Education

# We know education.

From nurseries and children's play areas, to colleges and universities, we're committed to raising the standard of children and young adults' washrooms.

## Safety

Children have a right to be safe at all times. With this in mind, we've introduced a number of important features into our designs. Low-level and shaped door options allow adult supervision where it's needed, while our clever safety hinges mean an end to trapped fingers. Our emergency release indicator bolts also come as standard across our education range, giving you extra peace of mind.

## Privacy

Safety may be one of our top priorities, but we also believe that children have a right to privacy. That's why we give you the option of full height and increased privacy cubicle systems for secondary and further education. Not stopping there, our solutions also include urinal privacy screens.

## Colours

Children love colour and bold designs, which is why we've created the widest and brightest palette featuring 34 fresh and vibrant colours, ensuring you can create a washroom that children will enjoy using. Get creative with education washroom colour by requesting a copy of our Colour Selector brochure by visiting [www.venesta.co.uk/resources](http://www.venesta.co.uk/resources).

## Hygiene

A hard-working washroom should also be one that's easy to maintain. That's why our solutions include features that make cleaning really easy. These include our washtroughs with individual drainers and minimal joints. Also, the Solid Grade Laminate we use is totally impervious to water, which means it can withstand regular cleaning.

## Anti-tamper

At Venesta, we work hard to ensure our stylish and robust designs encourage respect and discourage vandalism. Our solutions for secondary and further education washrooms feature metal frames renowned for strength and rigidity with durable metal fittings.

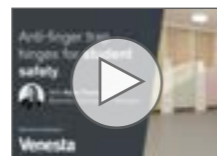

See our anti-finger trap hinges in action by watching our dedicated video on our YouTube channel.



## 01 Bold designs

With 34 fresh and vibrant colours to choose from, you can create washrooms that children enjoy using.

## 02 Total privacy

Full-height designs with low floor clearance for maximum student privacy.

## 03 Easy cleaning

The Solid Grade Laminate we use is totally impervious to water.

## 04 Right to feel safe

Low-level and shaped door options allow for adult supervision.

## Education 2-11 years

Our design team has gone to town creating spaces that challenge and delight young minds. Our Lollipop, Genesis and Award Low-Level cubicle ranges are perfect combinations of fun, safety and hygiene. Our wide range of finishes enable you to get creative with colour for schools, crèches and children's play areas.

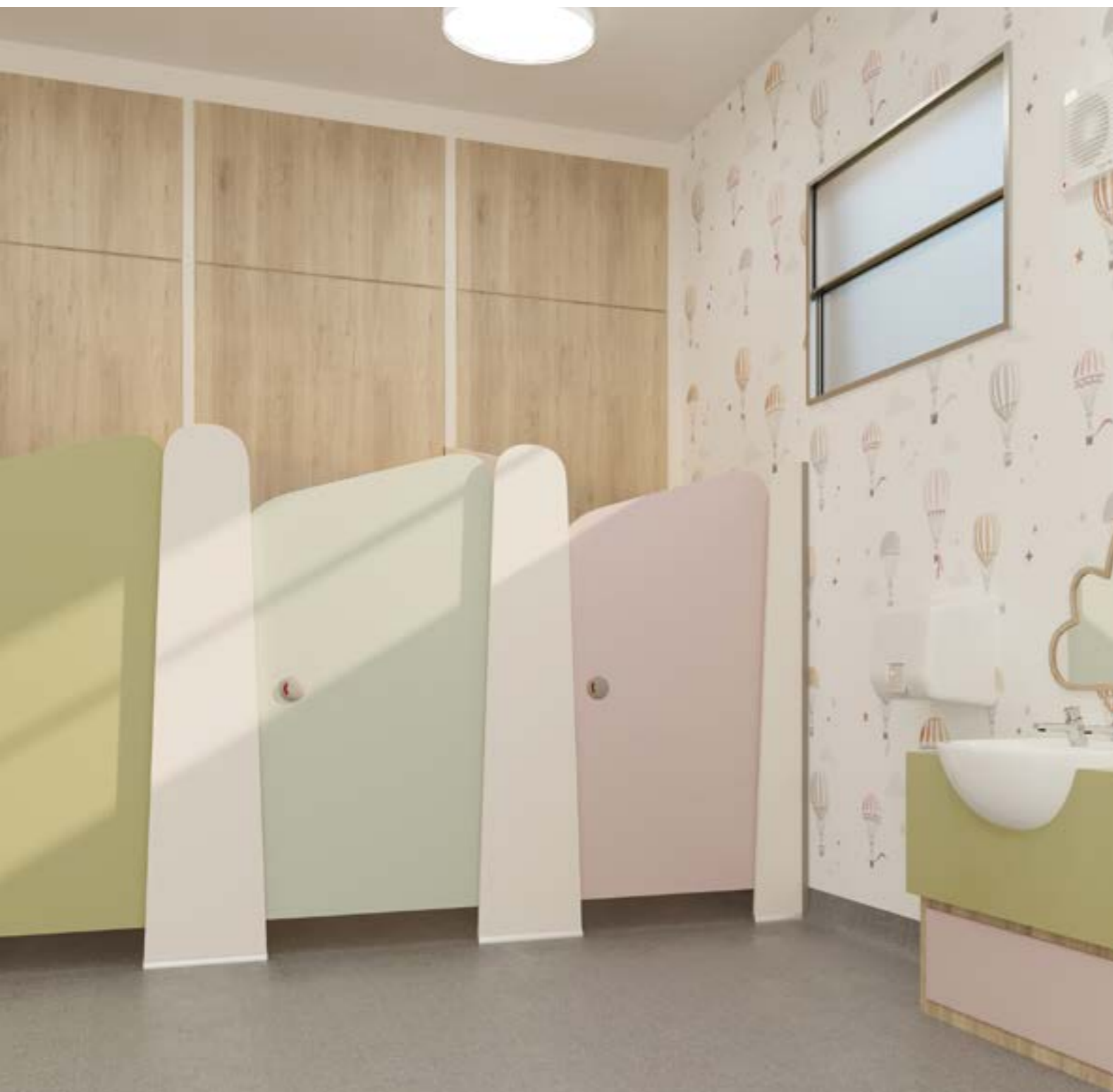

See our Education brochure for more details.



### Door heights

Balancing privacy needs with the need to supervise children is something we carefully consider with all our education washroom designs. The option of shaped and low height doors ensures you can achieve both.



**01** Door height B  
Genesis HPL cubicles in Merlot, Peony, Macaroon and Suede, Vepps HPL WC panelling in Suede and Peony and WT4 slim profile Solid Surface washtrough in Everest with Merlot HPL underframe and panels.

**02** Door height A Award Low-Level HPL cubicles in Indigo, Pacific, Hydrangea, Peacock, Teal and Cloud. Vepps HPL WC panelling in Cloud and Porcelain.

**03** Genesis door heights.

**Main image**  
Lollipop HPL cubicles in Olive, Duck Egg, Peony and Suede, with Vepps WC panelling in Soft Oak and Suede. HPL vanity in Olive, Peony and Soft Oak with Sandringham 21 semi-recessed basins and Sandringham 21 self-closing pillar taps.

## Case Study Alexander McLeod Primary School

**“The Genesis cubicle range was the perfect solution for this primary school, plus the wide range of colours gave the school total design flexibility.”**

Tony Starr, A F Starr

South East London-based Alexander McLeod Primary is a school where students model the high expectations and standards that are promoted at all times. The school aims to create an environment where all children can grow and flourish.

During a recent renovation project, attention was turned to the student washroom facilities. The existing toilet cubicles and vanity units were antiquated and hard for the facilities team to maintain, resulting in an uninviting space for the students to retreat to.

We worked with builders A F Starr to ensure fit-for-purpose education washroom systems were specified for the younger years children. There was a requirement for washroom solutions that would be easy to clean and maintain whilst giving the staff the ability to supervise younger children using the facilities, where necessary.

Our popular Genesis toilet cubicles were specified in Solid Grade Laminate (SGL) in our Duck Egg and Suede finishes. Not only is SGL water and scratch proof, but its smooth surface will allow the school to uphold strict cleaning regimes to keep the school toilets sanitary for students.

With 1300mm high cubicle doors and shaped partitions, staff will be able to supervise students when required. Genesis' anti-finger trap hinges and emergency release indicator bolts made it an ideal cubicle choice.

The primary school opted for complementing SGL vanity units in matching colours. With its hardwearing, durable properties, SGL guarantees long-lasting washroom systems in busy environments such as schools.

Read the full case study at [www.venesta.co.uk](http://www.venesta.co.uk)

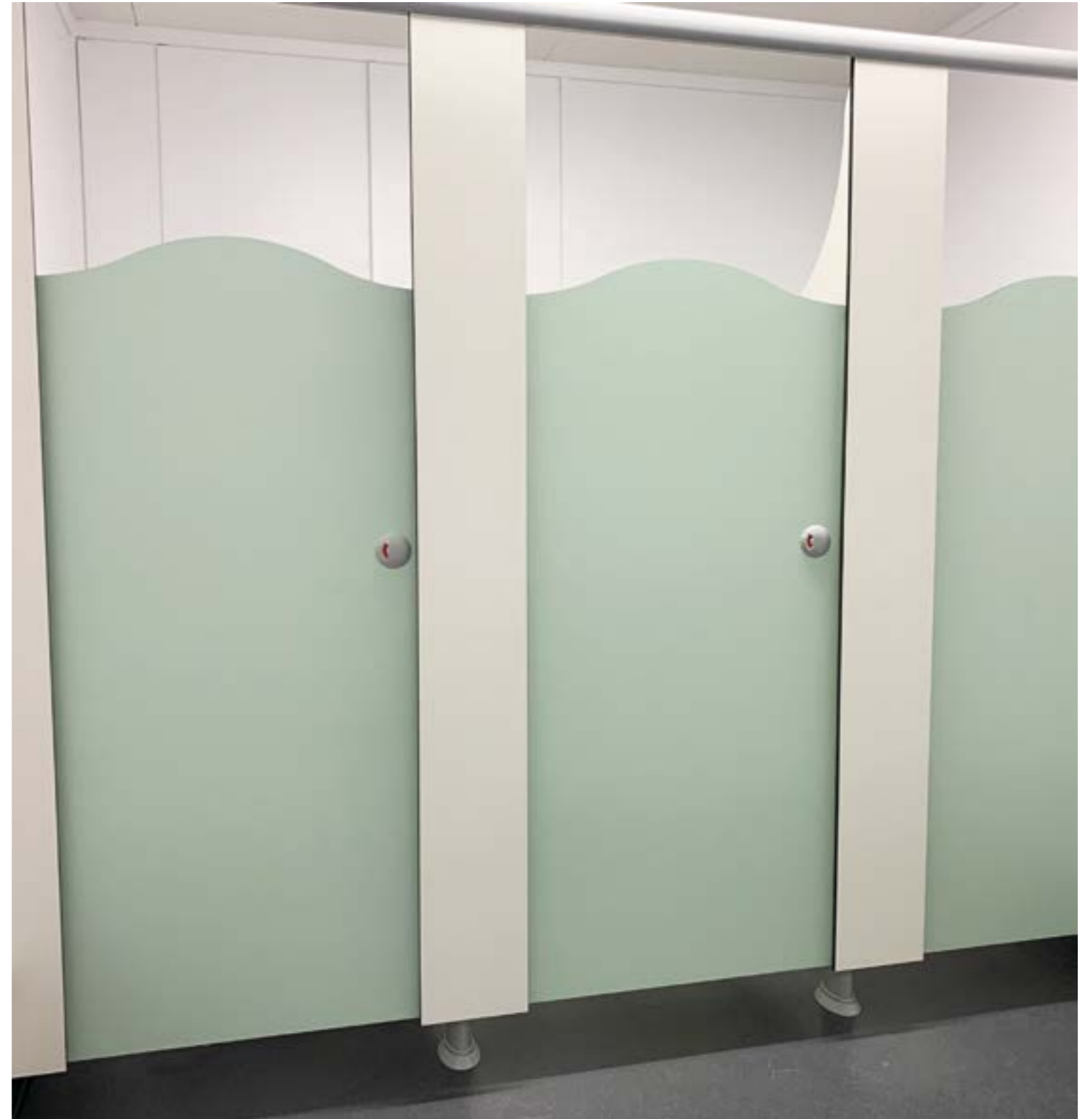

# Education 11+ years

Cleanliness, ease of maintenance, privacy, vandal resistance. With tough demands like these, you'll be glad to know we build these things into our designs as a matter of course. The results speak for themselves.

See our Education brochure for more details.



01

02

03

**01** Award, see p44-51.

**02** Unity, see p16-25.

**03** Centurion Full Height, see p72-73.

**Main image** Titan, see p36-43.

Specialist ranges

## Case Study Isaac Newton Academy

**“Venesta’s products are great value and the staff are helpful and committed; their full height cubicles are ideal for areas where privacy is essential.”**

Akos Juhasz, Architect

Rated outstanding by OFSTED, Isaac Newton Academy is a high-achieving school that accommodates boys and girls aged between 11 and 18 years. The academy's new washroom areas needed to be as secure and private as possible for students, whilst looking bright and inviting to use. The facilities also needed to offer staff the ability to easily supervise the communal areas.

Skanska managed the design and build of the Academy and the unisex washroom facility was located in an open area and had to be easy to supervise, offering complete visual and audible privacy for the pupils.

Our Unity toilet cubicle system was chosen by the client due to its seamless, flush-fronted design and full-height doors which allow for total privacy. Unity also has a low floor clearance for added privacy and robust fittings, making the toilet cubicles hardwearing and durable for those bustling school washrooms.

The indicator bolt has a discreet emergency release provision, making it the ideal choice for education environments, where safety is paramount. These cleverly designed indicator bolts mean emergency access can be gained without the need for removing or damaging the cubicle doors.

**Read the full case study at [www.venesta.co.uk](http://www.venesta.co.uk)**

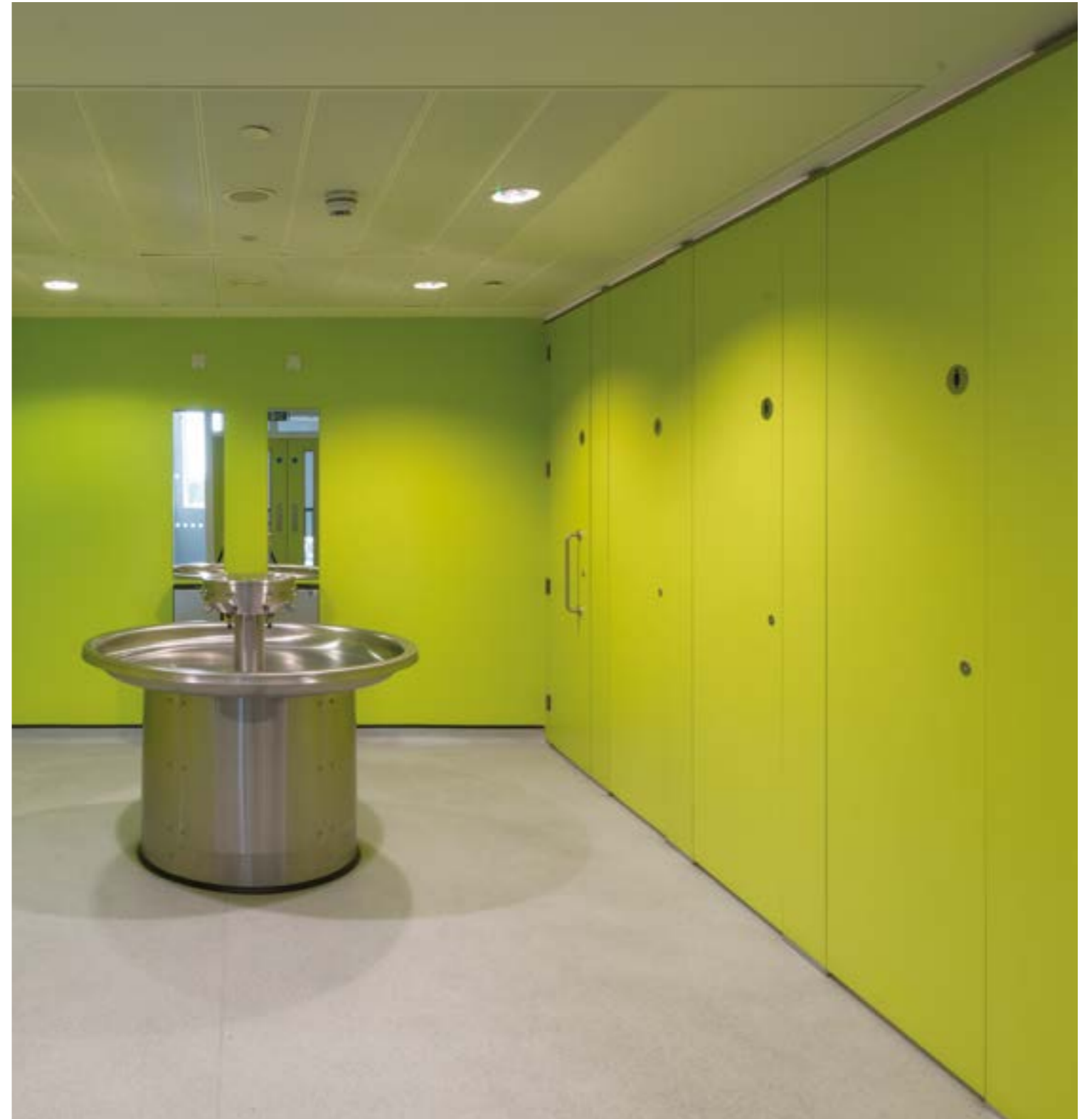

**We know healthcare.**  
We've been supplying the healthcare sector for almost 60 years. From small refurbishments to new buildings, we provide the highest quality solutions that are fit for purpose and completely compliant.



## Healthcare

In healthcare, compliance is key. Rest assured, our Vepps Healthcare systems meet the industry's requirement for fully compliant, tested and proven solutions, including HBN 00-10 Part C. Not only that, we have the knowledge and the expertise to guide you through every stage of the specification process.



**01** Vepps Hygen Plus Unit's satin anodised aluminium corner extrusions for added durability.

**02** Markwik electronic thermostatic mixer tap with proximity sensor.

### Main image

Vepps Wall System  
HPL panelling  
configuration with Dark Grey grab rails and White supported back rest.



## Vepps Hygen Plus Unit

**Designed with infection control in mind, Vepps Hygen Plus is a rigid and stable system that's totally impervious to water and is easy to clean and maintain.** With all the same benefits of Vepps Hygen, Hygen Plus' satin anodised aluminium corner extrusions offer additional strength to our newest healthcare IPS solution.

**01** Vepps Hygen Plus Unit in Teal with Contour 21 500mm wall hung washbasin and Markwik 21+ healthcare lever tap.



### Key features Hygen Plus Unit

Satin anodised aluminium corner extrusions offer additional strength.

A more flexible solution with the option of bigger units compatible with a wide range of sanitaryware, brassware and fittings.

Varied and versatile healthcare IPS layouts to suit your brief.

A choice of full or shelf height units.

Vepps Hygen Plus offers a between walls solution.

A HBN 00-10 Part C compliant system.

Options for larger access hatches for easy ongoing maintenance.

A fully compliant, tested and proven healthcare IPS solution.

An ultra strong aluminium frame.

Quick and easy install times with our ingenious click-fix mechanism.

Maintains integrity of rear fire walls and acoustic rated walls.

Optional plinth to allow vinyl flooring to be received.

A choice of 34 on-trend laminate finishes, including wood effects.

### Performance Options

#### Width

Hygen Plus: 700mm or 750mm\* as standard.

Hygen Plus multi-panel: Available between 800mm - 1550mm widths (50mm increments).

#### Height

Up to 2750mm

#### Depth

150mm or 225mm

#### Ceiling

Suspended and solid options.

#### Floor

Optional 100mm high skirting available to allow flush installation of vinyl flooring.

\*Other widths available on request.

## Vepps Hygen Unit

**Designed with infection control in mind. HBN 00-10 Part C Compliant.**

Vepps Hygen is a standalone sanitaryware assembly, formed from a single piece of Solid Grade Laminate. Vepps Hygen is impervious to water and easy to clean and maintain, thanks to its seamless design, flush fitting hinged and lockable access doors.



**01** Vepps Hygen Unit with Contour 21 500 panel mounted basin and Markwik 21+ wall mounted thermo mixer tap.

### Key features Hygen Unit

Manufactured from one piece of Solid Grade Laminate (SGL) creating a smooth, seamless finish for easy cleaning.

Integrated seal, designed to prevent water, vapour and airborne particles passing through the rebate.

Recessed, flush hinged and lockable access panels for ease of maintenance with allocated space to allow soap and towel dispensing units to be fitted.

Galvanised steel tie back rods complete with zinc brackets ensure a rigid and stable system.

A simple easy click wall system with concealed aluminium wall fixing channels, complete with galvanised, zinc plated steel joggle brackets for quick installation.

Maintains integrity of rear fire walls and acoustic rated walls.

Pre-plumbed and compatible with market leading sanitaryware, with more than 120 variations to choose from.

Wash hand basin assemblies have an option for a larger access hatch.

Available in all 34 standard laminate finishes.

### Performance Options

#### Width

700mm or 750mm

#### Height

Up to 2740mm

#### Depth

150mm or 225mm

#### Ceiling

Suspended and solid options.

#### Assemblies options

Clinical Sink (ST A, ST B, ST C), Clinical Wash Hand Basin (LB H M), Disposal Unit (D U), Disposal Unit (DU H), Hand Rinse Basin (LB G S), Janitorial Unit (JU), Non-Clinical Sink (SK 1, 2), Non-Clinical Wash Hand Basin (LB G M, LB G L), Plaster Sink (PS H), Scrub-Up Trough (SUH1), Shower (TM1), Unassisted Bath (BA G), Urinal (UR), WC (WC H, WC HD).

## Vepps Recessed Unit

A cost-effective solution that doesn't protrude into your room and is fully compliant with HBN 00-10 Part C. Vepps Recessed Units have been specifically designed to maintain up to 44Rw dB sound installation of standard partition walls and avoid the need for interface at both the floor and ceiling junctions.

**01** Vepps Recessed Unit with Contour 21 500 washbasin and Markwik electronic thermostatic mixer tap with proximity sensor.



### Key features Recessed Unit

Fully compliant with regulatory requirements.

Metal-framed, pre-plumbed system.

Factory-fitted and tested sanitaryware.

Hinged and lockable access panels with discreet tamper proof panel lock for maximum security.

Extruded aluminium framework.

Industry leading design with proven track record.

Space saving panel unit does not protrude into the room.

Avoids need for interface at floor and ceiling junctions.

Maintains up to 44Rw dB sound installation of standard partition wall.

Most cost-effective solution.

## Vepps Boxed-Out Unit

Offering you a speedy and simple installation, our Vepps Boxed-Out Units maintain integrity of rear fire walls and acoustic rated walls. With variable box depths, widths and heights to accommodate service requirements, this is our fully compliant, tried and tested solution.



**Main image**  
Vepps Boxed-Out Unit with Contour 21 500 washbasin and Markwik sequential mixer tap.

### Key features Boxed-Out Unit

Fully compliant with regulatory requirements.

Factory-fitted and tested sanitaryware.

Industry leading design with proven track record.

Factory-assembled Solid Grade Laminate boxed-frame can be installed first to allow floors and ceiling to be finished.

Box sides rebated into an extruded aluminium frame to provide a flush, easy to clean surface.

Variable box depth to accommodate service requirements.

Maintains integrity of rear fire and acoustic rated walls.

Avoids the need to co-ordinate aperture sizes and positions with partitioning contractor.

Pre-plumbed panel installed at later stage to avoid construction damage.

Offers speedy and simple installation.

Maximum height of 2770mm.

Vepps panelling available in SGL, HPL and MFC.

Vepps panelling and box frame available in 34 laminate colours.

Vepps 7 secrets apply to panels, excluding baserail.



**Main image**  
Vepps Hygen Plus Unit in Teal with Contour 21 500mm wall hung washbasin and Markwik 21+ healthcare lever tap.

## Case study The Royal London Hospital

**“Venesta’s product is both quick and easy to install, this, combined with an experienced CAD and manufacturing team makes them the ideal choice when procuring a washroom package of this size and complexity.”**

Marcus Lynes, Shire Integrated Systems Ltd (Installers for Skanska)

Part of Barts and The London Hospital Foundation Trust, one of Britain's leading healthcare providers, The Royal London Hospital at Whitechapel and St Barts Hospital at St Paul's both have a reputation for making outstanding contributions to modern medicine.

During an extensive new building scheme Venesta was chosen to supply new washroom and shower solutions throughout the two hospitals. These were both huge projects and a challenge that we relished.

To ensure smooth running, we provided a full-time project manager who was responsible for the surveying, scheduling and production drawing of every unit supplied.

The client chose a pre-plumbed panelling system and Quantum SGL cubicles. The latter's Solid Grade Laminate panels are extremely resistant to impact and impervious to water, making it an ideal solution for healthcare environments. Our pre-plumbed panelling system complies with HTM64 (superseded by HTM10) ensuring the very highest levels of hygiene and infection control.

The quality of our service was crucial to the success of this project. We offered a short lead time on all products, ensuring our client had total peace of mind, knowing that deadlines could always be met, even when unforeseen problems arose onsite.

**Read the full case study at [www.venesta.co.uk](http://www.venesta.co.uk)**

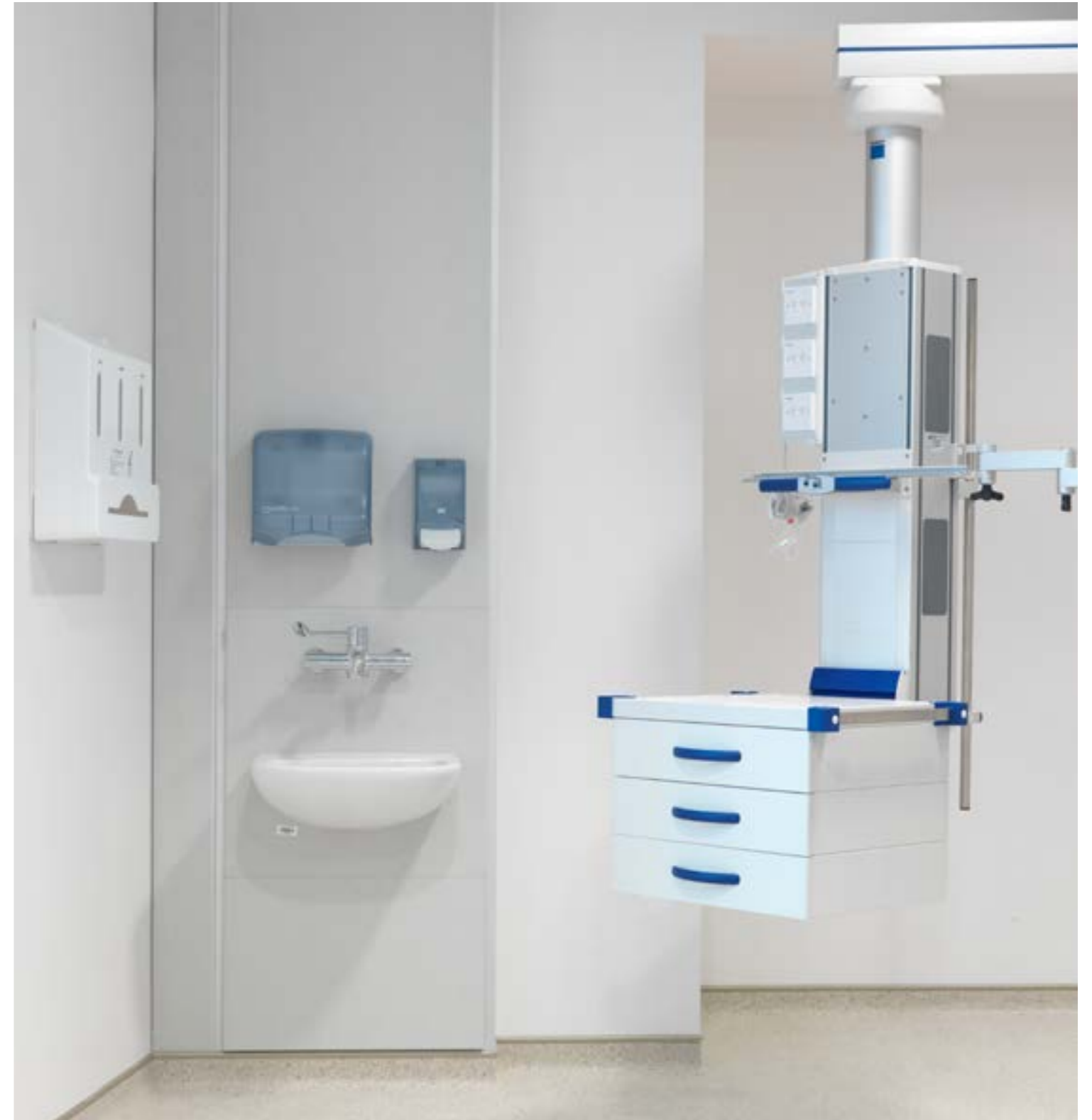

## Case study Oldham Community Diagnostic Centre

Each Vepps Healthcare unit was pre-plumbed and tested at the Venesta factory, reducing installation time by 50% and giving the end user added peace of mind.

Part of a national programme to expand access to diagnostic tests closer to home, the Oldham Community Diagnostic Centre is one of several purpose-built CDCs created to speed up diagnosis and relieve pressure on hospitals.

The Northern Care Alliance NHS Foundation Trust needed a solution that could guarantee durability, infection control and ease of maintenance across multiple specialist areas. Venesta was specified for its Vepps Hygen and Hygen Plus systems, designed for the most stringent healthcare settings.

Vepps Hygen and Hygen Plus ranges were specified for their superior infection control features and pre-plumbed design, enabling a fast and consistent fit-out. Working with accredited installer T-IPS Washrooms, the system was delivered on time and to exacting standards across the facility.

Every element of the installation was designed with infection control in mind, from recessed panel details to pre-plumbed units that minimise manual handling. The T-IPS team worked efficiently to deliver a consistent, high-spec finish that met the Trust's expectations.

From initial specification to final fit-out, the project ran smoothly thanks to close collaboration between the NHS Trust, Venesta, MTX Contracts, the main contractor, and T-IPS. The result is a calm, modern, and clinically sound environment that's ready to support thousands of patient appointments each year.

Read the full case study at [www.venesta.co.uk](http://www.venesta.co.uk)

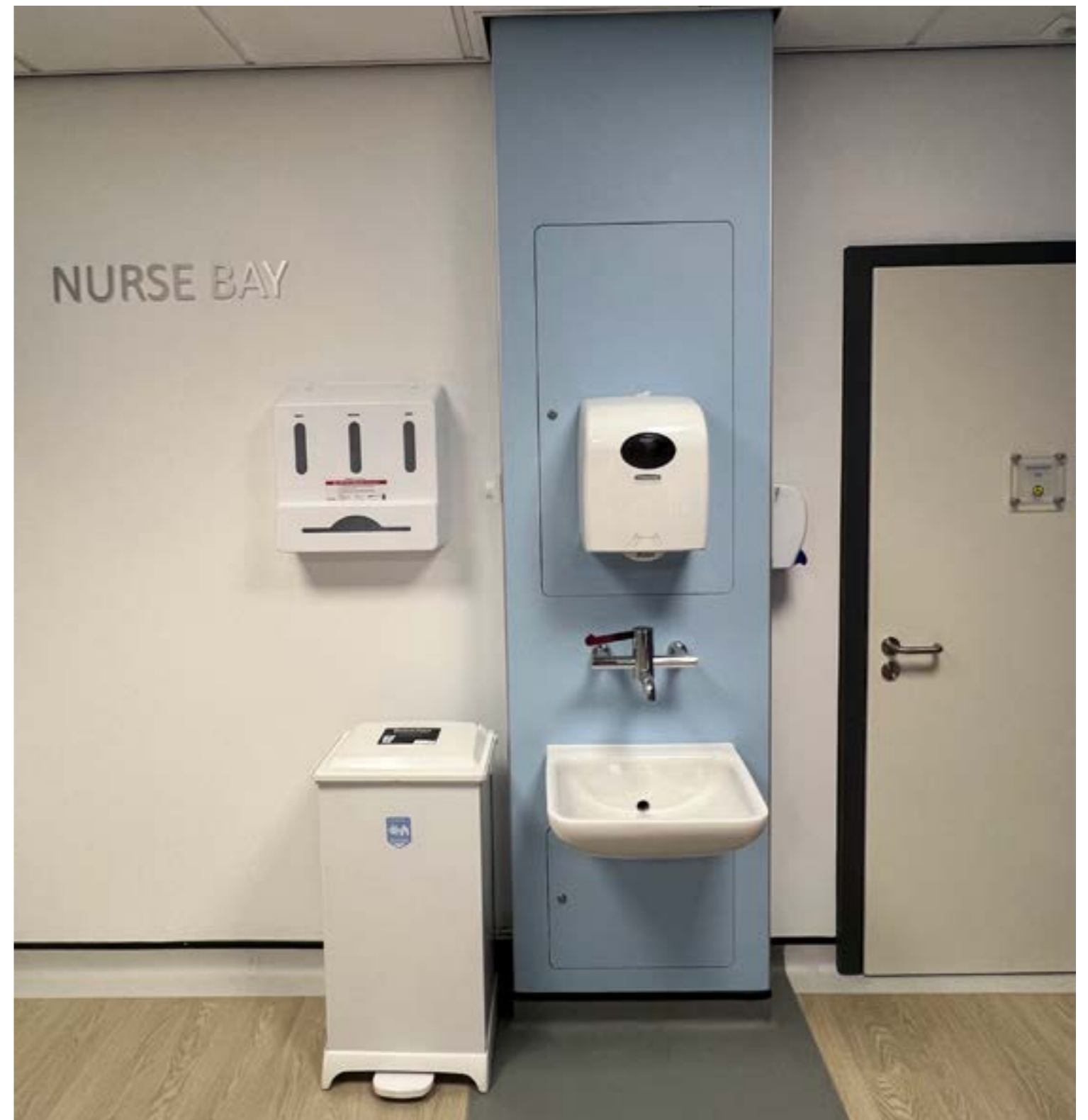

**We know sports and leisure.**  
We're passionate about raising the bar for sports and leisure centre washrooms. Your need for practicality in both wet and dry environments has prompted us to create a versatile range of safe, durable and innovative solutions, whatever your budget.



## Lockers and benches

For over 40 years, we've been designing and manufacturing lockers and benches for leisure centres and education environments. So whatever environment you're working in, you can rely on our stylish and flexible, tried and tested locker and bench solutions to seamlessly fit and perfectly enhance your space.



**Main image**  
Active Lockers,  
Model 2 & 3.

- 01** Internal coat hook.
- 02** 13mm SGL doors with integrated hinge design and SGL internal shelf.
- 03** SGL pocket benching.
- 04** SGL bench coat hook.
- 05** Cam lock.
- 06** Coin return lock.
- 07** Digi lock.
- 08** Coin retain lock.
- 09** RFID lock.
- 10** Hasp lock.

See p146-147  
for locker and  
bench technical  
specifications.



# Technical Specifying lockers and benches

## Lockers

**Active locker** 300mm width

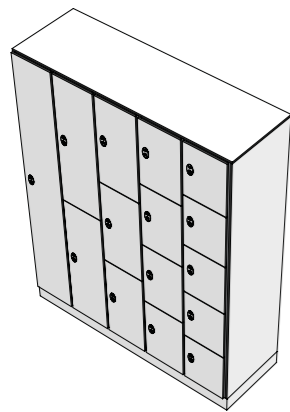

**Opening sizes**

- Model 1** 1774 x 262mm
- Model 2** 880 x 262mm
- Model 3** 583 x 262mm
- Model 4** 434 x 262mm
- Model 5** 345 x 262mm

**Active locker** 400mm width

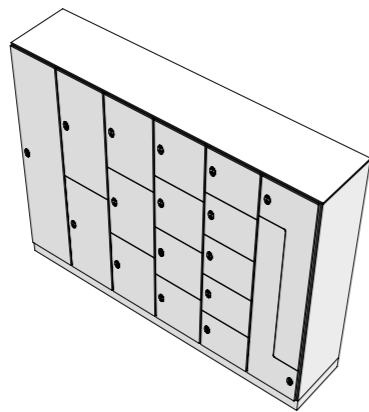

**Opening sizes**

- Model 1** 1774 x 362mm
- Model 2** 880 x 362mm
- Model 3** 583 x 362mm
- Model 4** 434 x 362mm
- Model 5** 345 x 362mm
- Model Z** 1457 x 362mm

**Bench locker** 300mm width

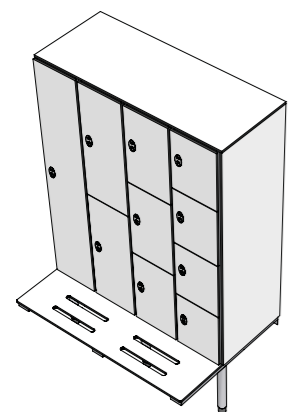

**Opening sizes**

- Model 1** 1434 x 262mm
- Model 2** 711 x 262mm
- Model 3** 469 x 262mm
- Model 4** 349 x 262mm

**Bench locker** 400mm width

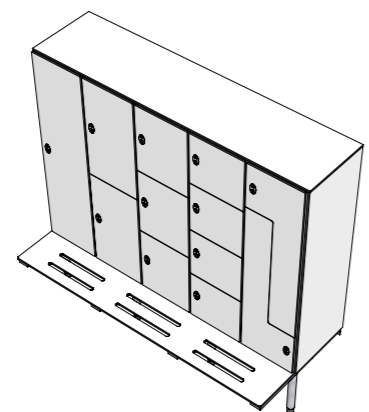

**Opening sizes**

- Model 1** 1434 x 362mm
- Model 2** 711 x 362mm
- Model 3** 469 x 362mm
- Model 4** 349 x 362mm
- Model Z** 1025 x 362mm

**Overall height**

Active lockers 1913mm  
Bench lockers 1473mm from bench level

**Widths**

300mm (not applicable to Model Z)  
400mm

**Depths**

500mm  
830mm (including bench)

**Active lockers key features**

- Available in 34 laminate colours
- Robust and hardwearing
- Practical in design and functionality
- High impact resistance
- Totally impervious to water

**Door performance**

High impact resistant 13mm thick Solid Grade Laminate (SGL) doors with 3mm radius corners.

**Body performance**

Robust, hardwearing and waterproof 3mm SGL carcass in Cloud.

**Dividers**

Hygienic, easy to clean 13mm thick SGL horizontal shelves in Cloud or Shadow.

**Hinge**

Rolled stainless steel self-closing hinge.

**Ventilation**

3mm space between doors and frame allows air to circulate.

**Locks**

- Coin retain
- Coin return
- Cylinder/cam lock
- Digi lock
- RFID lock
- Hasp lock

**Accessories**

- Laser cut numbers for locker doors
- Nylon coat hooks as standard with Model 1, Model 2 and Model Z lockers
- Nylon coat hooks as standard with Model 1 and Model Z bench lockers
- Corresponding wristband in red or blue

**Stands**

Venesta recommends that the lockers be installed on a raised concrete base in wet areas. Alternatively, the lockers can be mounted on a powder coated cantilevered bench. Please contact our sales team for details.

## Benches

Our benches have been designed to provide strength, safety and flexibility. Available in 2 materials (13mm SGL and 32mm hardwood) and in five profiles. Each benching solution has Light Grey (RAL9006) powder coated steel or stainless steel\* tubular framework.

Box section construction is tubular with adjustable feet and hidden fixings.

These bench systems are ideal for any of our washroom or cubicle systems, in both wet and dry environments.

\*Contact our friendly sales team on 01474 353333 for details on prices and lead times.

**Perimeter**



**Perimeter cantilever benching**



**Freestanding benching**



**Island benching**



**Locker benching**

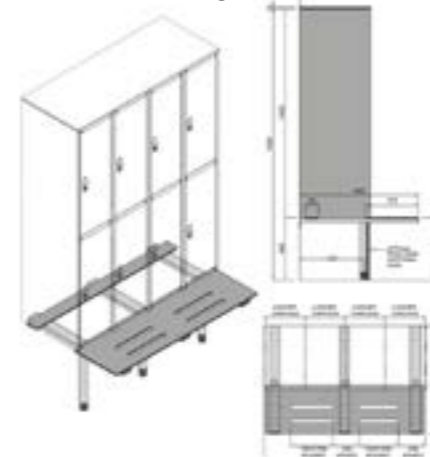

**Benching key features**

- Hardwearing SGL and hardwood benching options available
- Available in five profiles, each with tested tubular framework
- Ideal for wet and dry environments
- Designed for high level use
- Adjustable feet to suit uneven floors
- Optional shoe rack detail available
- Optional cubicle anti-peep rail detail available to complement coat hooks

**Profiles**

- Perimeter benching
- Perimeter cantilever benching
- Freestanding benching
- Island benching with integral coat hooks
- Locker benching

**Dimensions**

440 or 460mm bench height.

**Performance**

Hardwood slats in beech or SGL solid or pocket benches with double corrosion protected Light Grey powder coated steel or stainless steel\* tubular frame.

**Wall mounted coat hooks**

13mm SGL or 20mm hardwood coat rails in beech, with satin anodised aluminium coat hooks.

\*Contact our friendly sales team on 01474 353333 for details on prices and lead times.

**SGL wall mounted coat hooks**



**Hardwood wall mounted coat hooks**



**We know custodial cubicles.**  
Designed to suit the specific needs of custodial environments, our strong and durable Prison toilet cubicles feature robust core materials and fittings as standard to ensure the safety of inmates and staff.



## Prison cubicles

Our durable Prison cubicles are available in scratch, impact and water resistant SGL, with robust anti-tamper fittings as standard to ensure the safety of inmates and staff. Our Prison toilet and shower cubicle range meets the most stringent specifications of strength, durability, safety and hygiene.



01

**01** Continuous satin anodised aluminium floor to ceiling posts offer added cubicle strength and rigidity. The posts come with robust and secure fittings for maximum safety and security.

**02** For user safety, our emergency release indicator bolts allow quick and safe access to inside locked cubicles.

See p152-153 for Prison technical specifications.



02

### Main image

Prison SGL toilet cubicles in Cornflower Blue and Cloud with satin anodised aluminium fittings.

### Key features

Easy staff supervision thanks to reduced door heights

Continuous floor to ceiling posts for strength and rigidity

Bespoke cubicle sizes to suit your brief

Emergency release indicator bolts and anti-finger trap hinges as standard

All anti-tamper fittings are security fixings as standard to ensure safety

Water, scratch and impact resistant SGL is ideal for wet and dry environments

A choice of 34 laminate finishes for maximum design flexibility

# Technical Specifying Prison

## Dimensions

**Maximum height**  
1500mm

**Maximum depth**  
1900mm

**Floor clearance**  
150mm

## Performance

Available in one material option, our Prison cubicles are suitable for every type of wet or dry custodial environment, allowing you to specify an appropriate option to meet site requirements and your budget.

**SGL**  
Solid Grade Laminate is extremely resistant to impact and all surfaces are impervious to water. Panels are 13mm nominal thickness with polished black radiused edges.

## Detailing

**Panels and doors**  
Available in SGL.

**Colour finish**  
**SGL**  
34 colours from the standard range.  
**Cubicle hardware**  
Satin anodised aluminium.

**Edge treatment**  
**SGL**  
Polished black radiused edge.

**Floor to ceiling posts**  
Satin anodised aluminium floor to ceiling posts with satin anodised aluminium effect floor fixings.

**Cubicle hardware**  
**Indicator bolt**  
Satin anodised effect powder coated zinc easy grip sliding bolt with emergency release facility and concealed fixings.

**Hinge**  
Satin anodised aluminium effect anti-finger trap hinge.

**Pedestal**  
Rigid satin anodised aluminium floor to ceiling posts are fixed to the floor with security pan head screws.

**Fixings**  
Partition to wall: Satin anodised aluminium angle.  
Pilaster to partition: Satin anodised aluminium floor to ceiling post with aluminium angles.  
Pilaster to wall: Satin anodised aluminium angle.  
Cubicle fixings: M6 pin torx security heads barrel bolts to pilasters and end panels.

Please note: All fittings provided are security fixings to suit the environment.

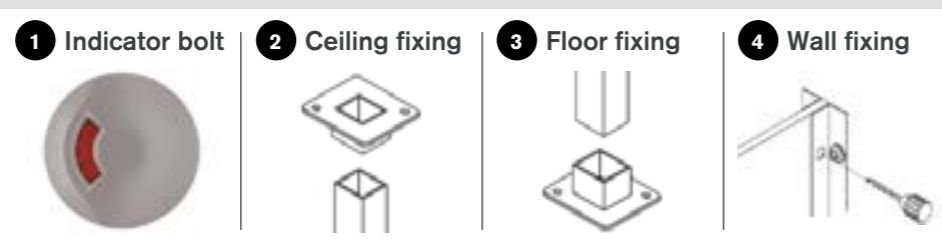
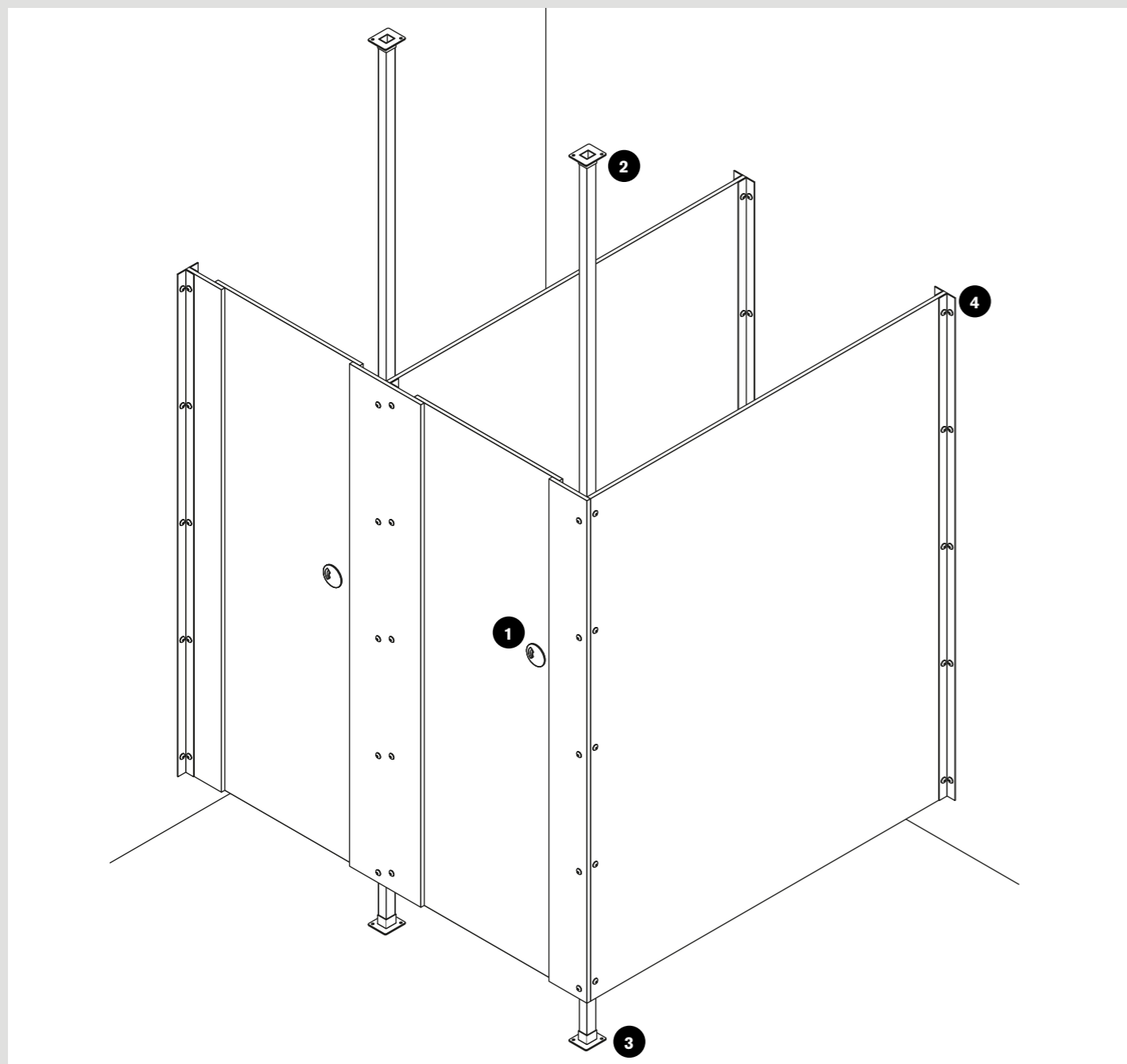

**Cubicle Express** Designed to meet your demands for the quickest and simplest washroom installation, this off-the-shelf solution is supplied to you within 48 hours. Supplied in oversized formats for onsite flexibility, this really is the hassle-free washroom solution.

# Cubicle Express



## The quickest and simplest installation is ready and waiting.

Promising you the winning combination of best value and uncompromising design quality, the Cubicle Express range includes cubicles, duct panels and vanities. All suitable for dry environments, the range features enlarged and ambulant cubicles with all the components and fixing instructions you need for a speedy build.

Available in oversized formats for onsite flexibility, Cubicle Express has a range of innovative features including channels that replace cleats and a new universal hinge. You can also choose from a selection of colours and shaped, low height doors, and have the option of our post-formed plaster too.

### Key features

- 48 hour delivery
- Flexibility - standard component sizes easily cut to suit site requirements
- Suitable for dry areas
- Four popular colour choices
- Robust fittings in Dark Grey ABS

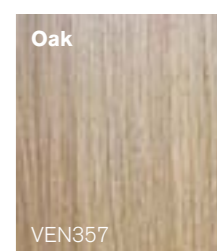
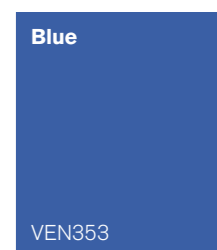
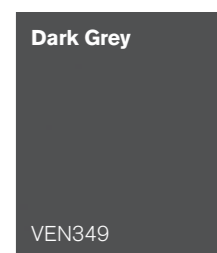

Specialist ranges

**01** Cubicle Express children's doors in Blue, with Dark Grey pilasters and partitions.

**02** UPVC wall channel and H-section.

See p158-163 for Cubicle Express technical specifications.

### Main image

Cubicle Express cubicles, duct panels and vanity.

# Technical Specifying Cubicle Express

## Dimensions

**Overall height**  
1950mm

**Floor clearance**  
100mm

**Maximum depth**  
1800mm

## Performance

Available in MFC, Cubicle Express is suitable for dry environments, allowing you to specify with confidence.

**MFC**

For dry environments with low risk of vandalism. Panels are manufactured from 19mm nominal thickness high performance moisture-resistant Melamine Faced Chipboard. Edges lipped with PVC.

## Detailing

**Panels and doors**

19mm nominal thickness Melamine Faced Chipboard (MFC).

Post-formed pilaster option: 19mm nominal overall thickness High Pressure Laminate (HPL) faced chipboard.

**Vanities**

19mm nominal thickness High Pressure Laminate (HPL) faced chipboard with 100mm front downstand and 75mm rear upstand.

**Flashgaps**

19mm nominal thickness Melamine Faced Chipboard (MFC) in a choice of 4 colours.

**Colour finish**

**Panels, doors and vanities**

4 colours.

**Cubicle hardware**

Dark Grey ABS.

**Edge treatment**

Matching lipping.

**Headrail**

Dark Grey U-section aluminium.

**Pedestal**

Dark Grey ABS.

**Accessories**

Accessories are in pack C1F. See p163.

## Duct panel packs

**Duct panels**

All framework by others. The installer needs to provide an appropriate timber-frame to support duct panels.

**P1 Washbasin and WC panel pack**

- 1 bottom panel 405 x 700mm
- 1 middle panel 670 x 700mm
- 1 top panel 1125 x 700mm
- 1 1mm PVC re-edging strip 2500mm
- 16 plastic clips and screws

**P2 Urinal panel pack**

- 1 bottom panel 225 x 700mm
- 1 middle panel 850 x 700mm
- 1 top panel 1125 x 700mm
- 1 1mm PVC re-edging strip 2500mm
- 16 plastic clips and screws

**P3 Plain panel pack**

- 1 plain panel 2250 x 700mm
- 1 1mm PVC re-edging strip 2500mm
- 10 plastic clips and screws

**P4 Plain panel pack**

- 1 plain 2250 x 300mm
- 1 1mm PVC re-edging strip 2500mm
- 10 plastic clips and screws

**F1 Flashgap pack**

- 2 flashgaps - unedged 2600 x 200mm
- 1 flashgap - edged 2600 x 201mm
- 16 shrinkage plates and screws

### Duct panels - standard height

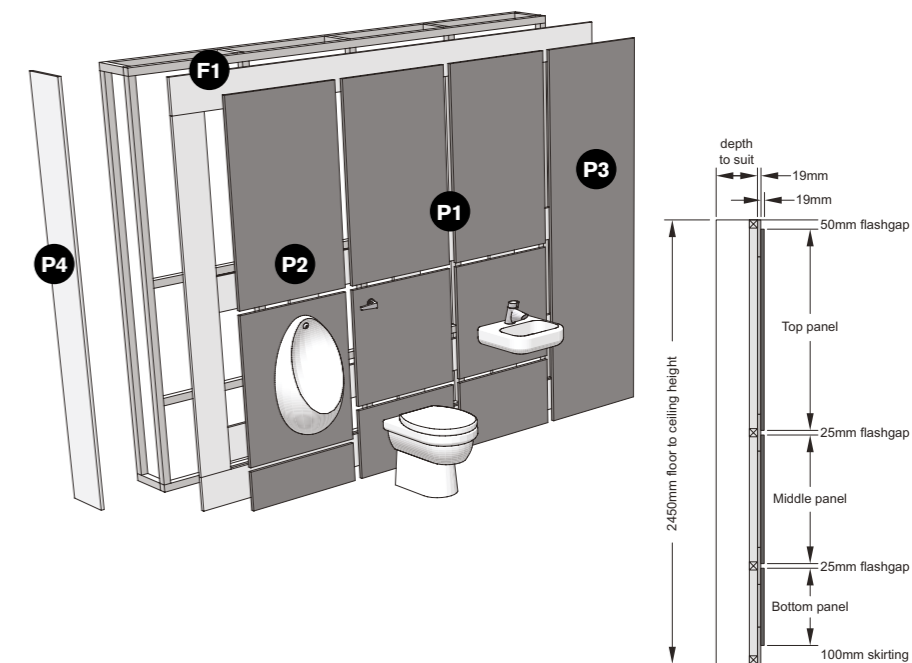

### Duct panels - shelf height

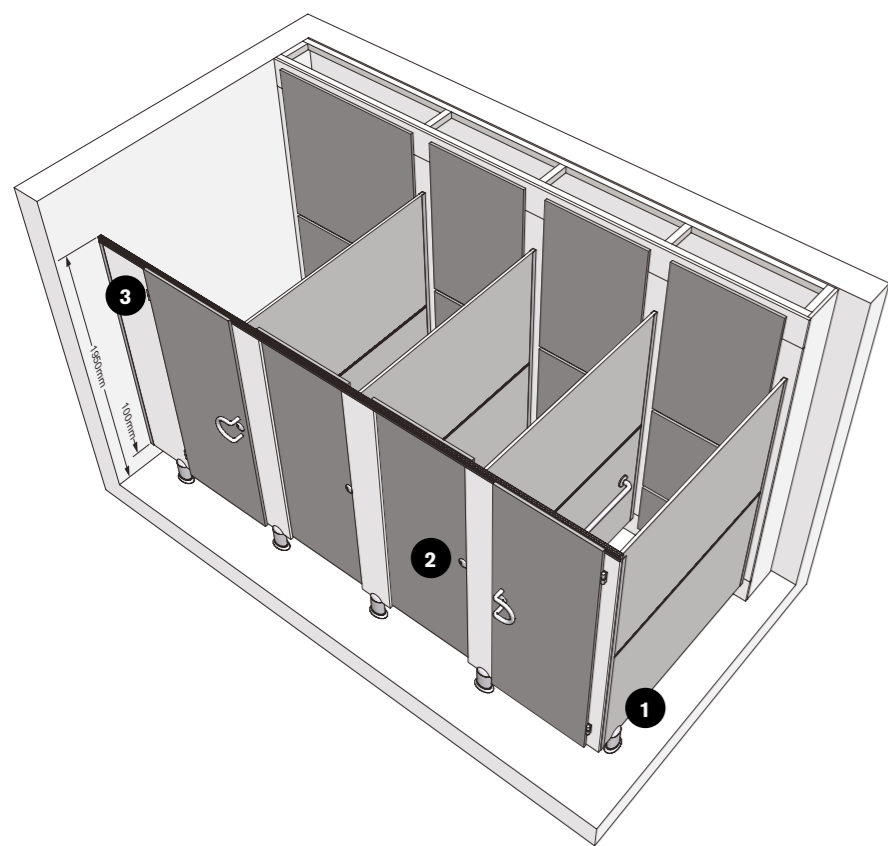
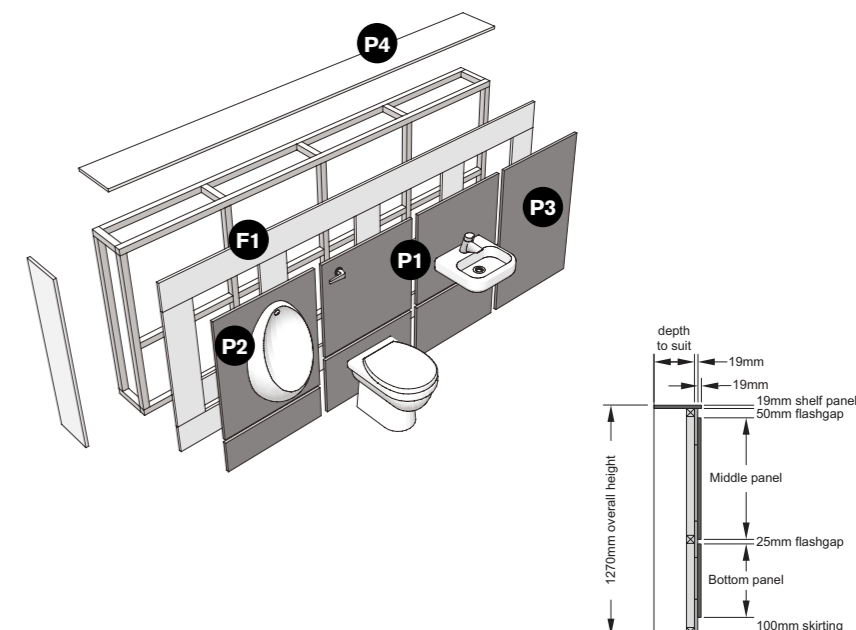

# Technical Specifying Cubicle Express

## Cubicle packs

### Cubicles

Wall channels accommodate out of line walls.

Door and wall channels allow for cutting without the need to re-edge.

Adjustments can be made to cubicles by reducing doors and partitions and fitting into full length door channels or wall channels as appropriate.

**Please note:** floor to ceiling post will be required when ordering free-standing cubicles.

#### C1 Door pack

- 1 Outward opening/inward opening wheelchair, ambulant and enlarged.
- 1 door 1850 x 900mm
- 1 square edge pilaster 1850 x 220mm
- 1 square edge pilaster hinged 1850 x 115mm
- 1 square edge pilaster no hinge 1850 x 115mm
- 1 square edge pilaster for enlarged cubicle drilled for hinge 1850 x 400mm
- 3 UPVC door cap/wall channels 1850mm
- 1 1800mm aluminium headrail in Dark Grey

(Door pack also available with post-formed pilasters - C1P)

#### C1F Fittings pack

- 1 indicator bolt
- 1 outward keep
- 3 hinges
- 1 toilet roll holder
- 1 coat hook
- 2 pedestals
- 2 buffers
- Screws, plugs and channel through fixings

### Cubicles

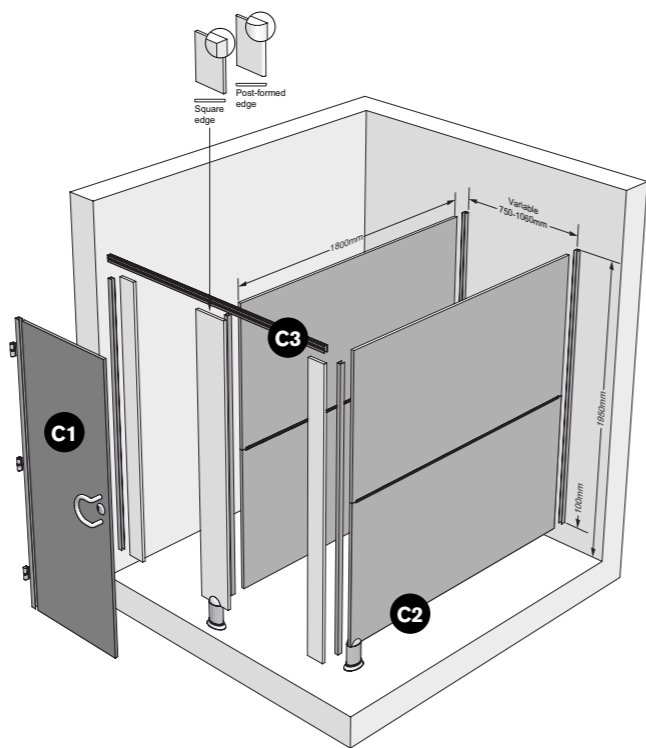

#### C2 Partition pack

- 2 partition 'halves' 925 x 1800mm
- 1 UPVC H-section
- 1 UPVC door cap/wall channel 1850mm

#### C3 Inline pack

- 1 large pilaster 1850 x 900mm
- 1 square edge pilaster drilled hinge 1850 x 550mm
- 1 1800mm aluminium headrail in Dark Grey

(Inline pack also available with post-formed pilasters - C3P)

#### C4 Floor to ceiling post

- 1 floor to ceiling post 3750mm
- 2 flanges
- Screws, plugs and channel through bolt fixings

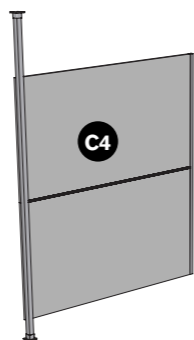

#### GR1 Ambulant/enlarged grab rail pack

- 3 grab rails, White powder coated 600mm
- 2 door opening handles Dark Grey powder coated
- 1 fixing pack complete

## Children's door and vanity unit pack

### Children's doors

#### C1C Children's door pack

- 1 door 1850 x 900mm
- 1 square edge pilaster 1850 x 220mm
- 1 square edge pilaster hinged 1850 x 115mm
- 1 square edge pilaster no hinge 1850 x 115mm
- 1 square edge pilaster for enlarged cubicle drilled for hinge 1850 x 400mm
- 3 UPVC door cap/wall channels 1850mm
- 1 1800mm aluminium headrail in Dark Grey

(Children's door pack also available with post-formed pilasters - C1CP)

### Children's doors

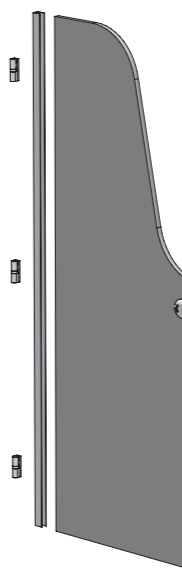

### Vanities

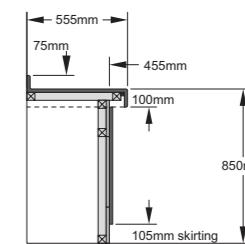
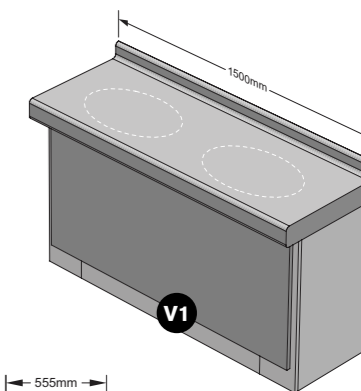

### Children's doors

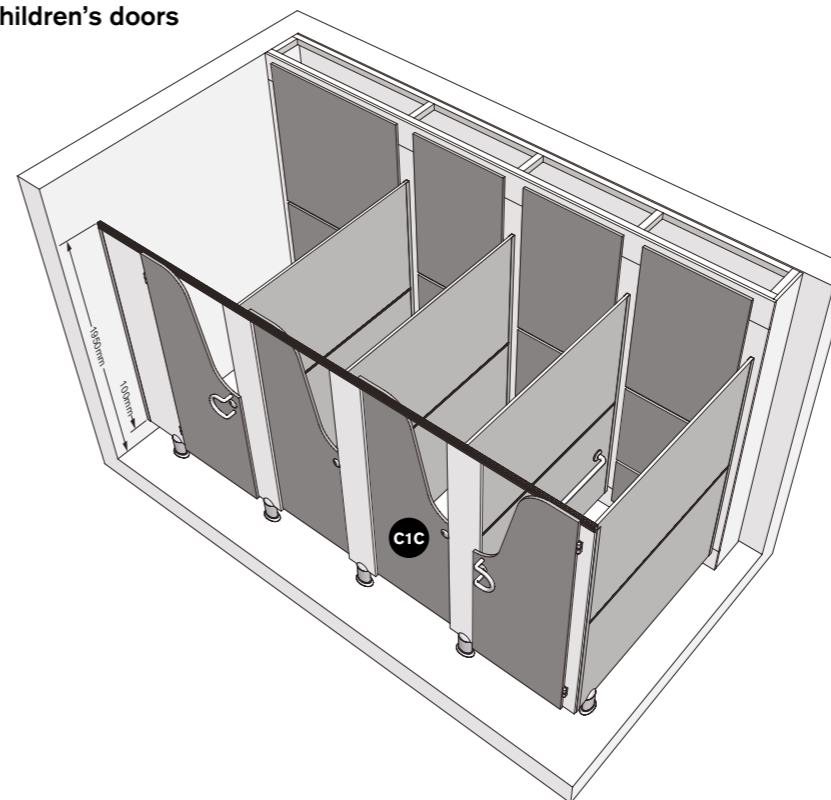

### Vanities

All framework by others. The installer needs to provide an appropriate timber-frame to support vanity units (typical example: 50 x 50mm treated softwood).

Longer vanities can be achieved by joining two lengths.

The return end panel for vanity units will be supplied oversized to enable the installer to make onsite adjustments.

#### V1 Vanity unit pack

- 1500 x 555mm top post-formed into a 100mm downstand and a 75mm high upstand blocked both ends
- 1 1400 x 645mm under panel
- Clips and screws
- 3 unedged flashgaps 1300 x 200mm
- Fixing brackets and screws
- 2 loose return ends

# Selecting Cubicle Express

Each product pack (cubicles, duct panels and vanity units) will be supplied fully boxed, clearly labelled, complete with all the necessary fixing components and installation instructions.

## Cubicle selection

- For each set of cubicles, identify which of the layouts suits your project, then refer to the grid beside it.
- Read across the top row of the grid until you reach the number of cubicles required.
- Read down the column under the number of cubicles to identify the pack and quantities you require.

**Please note:** minimum cubicle width 750mm.

### Options for all types

- Children's door instead of standard door pack.
- Ambulant/enlarged grab rails and door opening bars are available separately.
- Post-formed pilasters.

## Between walls

Number of cubicles	1	2	3	4	5	6	7	8
Door pack	1	2	3	4	5	6	7	8
Fittings pack	1	2	3	4	5	6	7	8
Partition pack	0	1	2	3	4	5	6	7
Floor/ceiling post pack	0	0	0	0	0	0	0	0
Maximum width - mm	1060	2120	3180	4240	5300	6360	7420	8480

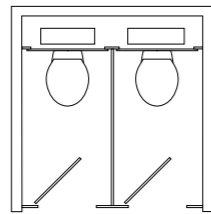

## Freestanding

Number of cubicles	1	2	3	4	5	6	7	8
Door pack	1	2	3	4	5	6	7	8
Fittings pack	1	2	3	4	5	6	7	8
Partition pack	2	3	4	5	6	7	8	9
Floor/ceiling post pack	1	1	1	2	2	2	2	2
Maximum width - mm	1060	2120	3180	4240	5300	6360	7420	8480

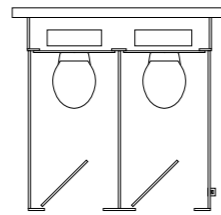

## In wall angle

Number of cubicles	1	2	3	4	5	6	7	8
Door pack	1	2	3	4	5	6	7	8
Fittings pack	1	2	3	4	5	6	7	8
Partition pack	1	2	3	4	5	6	7	8
Floor/ceiling post pack	0	0	0	0	0	0	0	0
Maximum width - mm	1060	2120	3180	4240	5300	6360	7420	8480

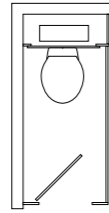

## Inline cubicle

	Between walls	In wall angle
Number of cubicles	1	1
Door pack	1	1
Fittings pack	1	1
Partition pack	0	1
Inline pack	1	1
Maximum length - mm	2000	2000

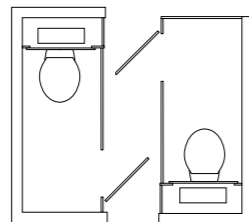

## Vanity selection

- Determine how many vanity basins you require in each top.
 

1500mm long top	Up to 2 basins	Pack V1
-----------------	----------------	---------
- Check that your chosen top will fit into the space available onsite.
- Each vanity pack includes under panel, return end and flashgap. These are all included along with fixings pack.
- The supporting softwood frame is supplied by others.

## Panel selection

- For each range of panels, determine how many you want of each type.
  - Always leave a vertical gap 25mm wide between a panel and a wall.
  - Leave a 25mm wide vertical gap between each panel.
  - For WC panels, leave 50mm for fixing a cubicle partition.
  - Plain panel packs P3 and P4 can be cut down and re-edged onsite to cater for ranges that do not accommodate 700mm modules.
- For each panel you will need one flashgap pack.

# Selecting Cubicle colours

With the flexible range of colours offered by Cubicle Express you can contrast pilasters, doors and partitions to create an attractive colour combination. Doors, partitions and duct panels are available in a choice of 4 popular colours.



# Accessories

Accessories are available from Venesta.

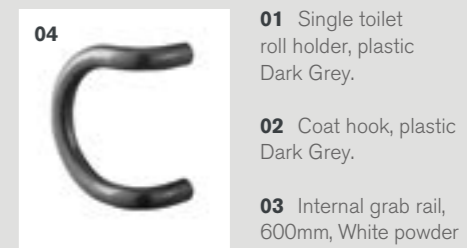

- 01 Single toilet roll holder, plastic Dark Grey.
- 02 Coat hook, plastic Dark Grey.
- 03 Internal grab rail, 600mm, White powder coated aluminium.
- 04 Exterior door handle, Dark Grey powder coated aluminium.

**We know panelling.**  
At Venesta, we're renowned for our innovations in panelling. From our Venesta Engineered Pre-Plumbed System, Vepps, to our cost-effective Rapiduct system, we have a fit for purpose solution to suit your needs.

# Panelling

**You're assured of the right solution. We know that every design scheme is different, so we've created three different solutions, each one carefully designed and manufactured with you in mind. Whether you need a made to measure, ready to install integrated system, or a basic, excellent value alternative, you can find it here.**

## Vepps

### Pre-plumbed

With over 120 years of washroom innovation, we introduce Vepps. Our revolutionary, fully engineered metal framed pre-plumbed system offers even faster installation, even easier ongoing maintenance and a much wider range of factory fitted sanitaryware, all at a lower cost. What makes Vepps unique is its linear-bearing hinges and support ratchets, offering easy access to duct space and effortless, smooth movement. A Venesta dowel dock ensures perfect panel alignment whilst zinc plated steel tie backs offer improved stability to the whole system. Vepps can be specified with any Venesta cubicle or vanity system. Plus it of course comes with Venesta's rock solid 10 year product guarantee.



## Frameduct

### Non-plumbed

If you're looking for a sturdy, metal-framed panelling system but want the choice of specifying your own sanitaryware, then Frameduct is the ideal solution. It's made to measure and features a click-fix mechanism so it's quick and easy to install. Frameduct can be specified with any Venesta cubicle or vanity system.



## Rapiduct

### Timber-framed

Simple, functional and cost-effective, this panelling system is flexible enough to suit any cubicle range. Unlike the other panelling options, Rapiduct is constructed onto a timber-frame, not supplied by Venesta, and is designed for your own build and installation. You can specify Rapiduct with any Venesta cubicle or vanity system.



**Your checklist to make specifying easy.**  
 From education to retail, healthcare to industrial, Venesta has a proven track record of supplying high quality panelling systems for the most demanding environments.

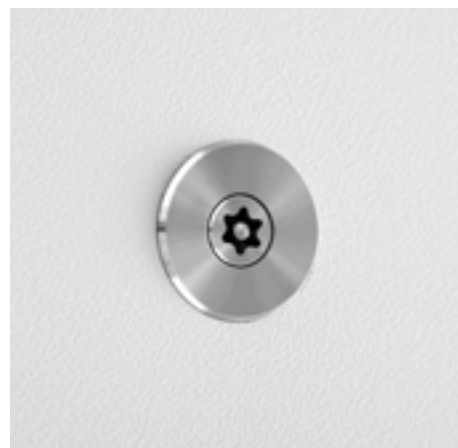

	Vepps	Frameduct	Rapiduct
<b>Benefits</b> To help you choose the right system for you, we've put together this at-a-glance benefits checklist.			
Factory fitted sanitaryware	•		
Choice of pre-plumbed WC suites, urinals, basins and vanity units	•		
Fully tested sanitaryware	•		
Speedy installation	•	•	•
Factory assembled, guaranteeing a quality product and finish	•	•	
Unique click-fix metal frame	•	•	
Metal framework, impervious to water	•	•	
Product longevity	•	•	•
Suitable for use with all types of sanitaryware		•	•
Lockable duct panel option	•	•	•
Conceals plumbing and services (wastes and traps)	•	•	•
Provides easy access for maintenance	•	•	•
Choice of board types and edge details, providing an offering to suit any application	•	•	•
Universal – it complements any cubicle range	•	•	•
10-year product guarantee	•	•	•
Venesta linear-bearing hinge and panel support ratchets for easy maintenance	•	•	

**Vepps 170**



**Frameduct 202**



**Rapiduct 208**



**A solution tailored to your needs**

**Vepps**  
 The choice for efficient and easy installation, Vepps is the ultimate made to measure metal, pre-plumbed system, perfect for whatever sector you're working in.

**Frameduct**  
 Our made to measure, ready to install metal, non-plumbed system has all the cutting edge features you need, but gives you the flexibility to choose your own sanitaryware.

**Rapiduct**  
 As the best quality, low-cost choice, Rapiduct offers you a well-crafted, functional system and the flexibility to choose your own sanitaryware.

**Vepps** gives you a ground-breaking pre-plumbed system that ticks all the boxes. It's simple, flexible and compatible with all products. Plus, it's adaptable enough to work across any sector.



**You need simplicity.**  
 Vepps is the industry's first precision engineered pre-plumbed panelling system with a click-fix assembly into an aluminium frame. That means installation is efficient and cost-effective.

**Simplicity.**

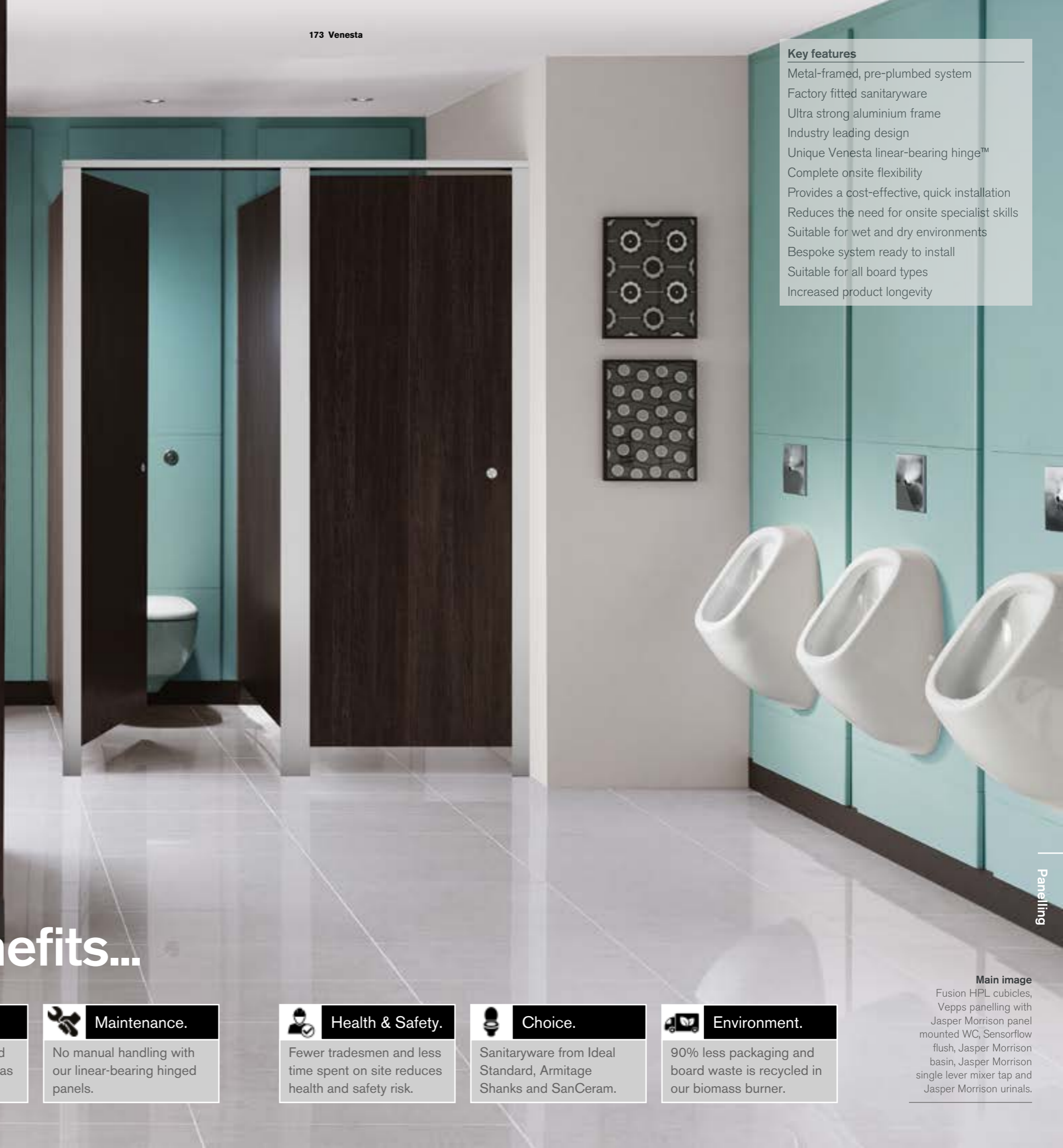

**Key features**

- Metal-framed, pre-plumbed system
- Factory fitted sanitaryware
- Ultra strong aluminium frame
- Industry leading design
- Unique Venesta linear-bearing hinge™
- Complete onsite flexibility
- Provides a cost-effective, quick installation
- Reduces the need for onsite specialist skills
- Suitable for wet and dry environments
- Bespoke system ready to install
- Suitable for all board types
- Increased product longevity

**With 7 unbeatable benefits...**

**Cost.**  
 Proven to be more cost effective over the whole project lifecycle.

**Onsite speed.**  
 Onsite installation 50% faster than traditional plain panel method systems.

**Quality.**  
 Perfect factory finish and panel alignment as well as a 10-year guarantee.

**Maintenance.**  
 No manual handling with our linear-bearing hinged panels.

**Health & Safety.**  
 Fewer tradesmen and less time spent on site reduces health and safety risk.

**Choice.**  
 Sanitaryware from Ideal Standard, Armitage Shanks and SanCeram.

**Environment.**  
 90% less packaging and board waste is recycled in our biomass burner.

**Main image**  
 Fusion HPL cubicles, Vepps panelling with Jasper Morrison panel mounted WC, Sensorflow flush, Jasper Morrison basin, Jasper Morrison single lever mixer tap and Jasper Morrison urinals.

# Choice.



**You need a wide choice of high quality sanitaryware.** From cutting-edge, designer sanitaryware to simple, budget options, our partnerships with Armitage Shanks, Ideal Standard and SanCeram give you the flexibility to choose industry leading products to complement your washroom.



**01** Vepps panel with Marden 525 wall hung basin and Aquarius A45 tap.

**02** Unity HPL cubicles and Vepps panels with Chartham BTW WC.

**03** Vepps panels with Marden concealed trap urinal and sensor flush.

**Main image**  
Vepps panels with Jasper Morrison basins, Jasper Morrison single lever mixer taps and Jasper Morrison urinals.



# Vepps Sanitaryware



**Contour 21+ back to wall rimless WC**  
S0439HY 410mm height



**Contour 21+ raised height back to wall rimless WC**  
S0440HY



**Contour 21 schools 305 back to wall WC**  
S304601 305mm height  
S304701 355mm height



**Contour urinal bowl**  
S611001 665mm height



**Jasper Morrison urinal bowl**  
E621501 580mm height



**Contour hygienic rimless urinal bowl**  
S611901 675mm height



**Sandringham 21 back to wall WC**  
E897401



**Concept back to wall WC**  
E050901



**Sandringham 21 wall hung WC\***  
V391001  
Requires Vepps WC Carrier



**Sanura urinal bowl\***  
S610001 500mm height



**Urinal division with hanger and screw**  
S612001 675mm height



**Contour 21+ wall hung rimless WC**  
S0443HY  
Requires Vepps WC Carrier



**Concept wall hung WC**  
E047301  
Requires Vepps WC Carrier



**Contour 21+ rimless back to wall WC**  
S0437HY 700mm projection  
S0438HY 750mm projection

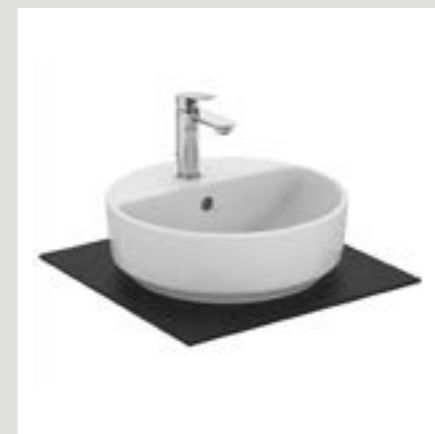

**i.life O 40cm Round Vessel Washbasin\***  
T5735(01) 1 tap hole



**Cherwell 21 380mm under-countertop basin\***  
S268701 No tap hole

\*Could incur extended lead times, please contact our friendly sales team for further information

Panelling

# Vepps Sanitaryware



**Solid Surface integrated basin\***  
810GWSK No tap hole



**Sandringham 21 500mm countertop basin**  
E895201 1 tap hole

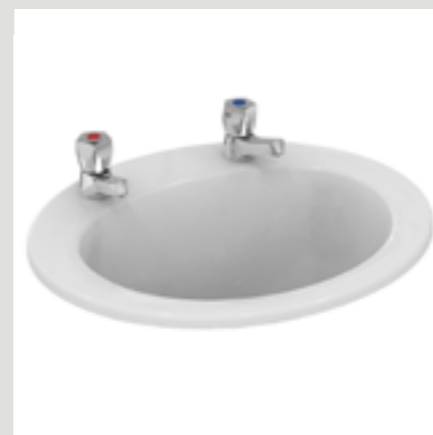

**Sandringham 21 500mm countertop basin\***  
E895401 2 tap holes



**Sandringham 21 500mm semi-recessed basin\***  
E895801 1 tap hole

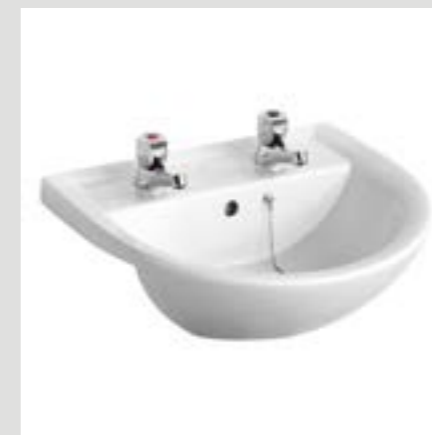

**Sandringham 21 500mm semi-recessed basin**  
E895901 2 tap holes



**Portman 21 500mm panel mounted basin\***  
S230801 Left tap hole



**Orbit 21 550mm fully inset basin**  
S248601 1 tap hole



**Orbit 21 550mm fully inset basin\***  
S248801 2 tap holes



**Jasper Morrison 550mm semi-recessed basin\***  
E620601 1 tap hole



**Portman 21 500mm panel mounted basin**  
S225401 Right tap hole



**Portman 21 500mm panel mounted basin**  
S231101 Centre tap hole



**Portman 21 400mm panel mounted basin**  
S215901 Left tap hole



**Concept 450mm semi-recessed basin**  
E797901 1 tap hole



**Profile 21 500mm semi-recessed basin**  
S249201 1 tap hole



**Profile 21 500mm semi-recessed basin**  
S249401 2 tap holes



**Portman 21 400mm panel mounted basin**  
S231401 Right tap hole



**Contour 21 370mm panel mounted basin**  
S212201 Centre tap hole



**Contour 21 370mm panel mounted basin**  
S247301 Left tap hole

\*Could incur extended lead times, please contact our friendly sales team for further information

# Vepps Sanitaryware and brassware



**Contour 21 370mm panel mounted basin**  
S247401 Right tap hole



**Contour 21 500mm panel mounted basin**  
S215401 No tap hole



**Contour 21+ 50cm back outlet basin (HBN 00-10 HTM64)**  
S0430HY



**Avon push button self closing bib tap\***  
S7241AA



**Sensorflow 21 compact wall spout 230mm**  
A4849AA Mains\*  
A4850AA Link\*



**Avon 21 push button self closing pillar taps**  
B8267AA Pair

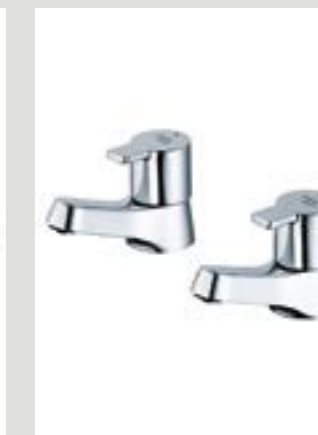

**Sandringham SL 21 basin pillar taps\***  
B3304AA Pair



**Sandringham 21 self closing pillar taps**  
S0672AA Pair



**Sandringham 21 lever pillar taps\***  
B9881AA Pair

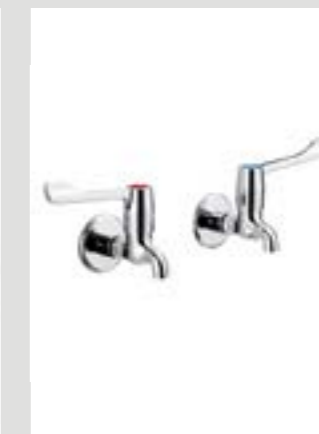

**Markwik lever bib taps**  
S8270AA Pair

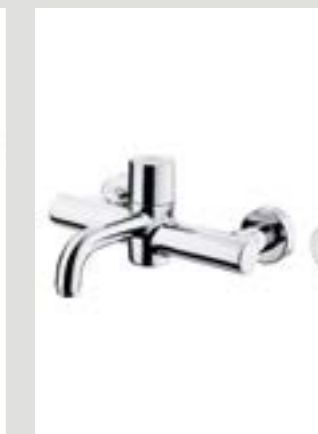

**Markwik 21+ panel mounted thermostatic mixer with time flow sensor**  
A6737AA Fixed spout\*

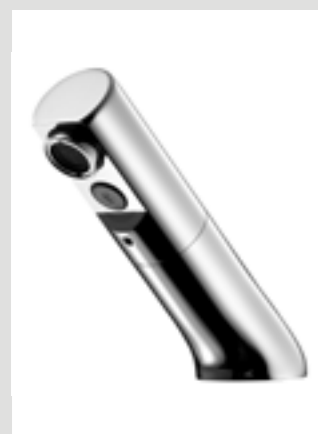

**Sensorflow 21 compact mixer deck mounted tap**  
A4852AA Mains  
A4853AA Link



**Sensorflow 21 electronic spout tap**  
A4171AA Mains  
A4172AA Link



**Contour 21 thermostatic sequential basin mixer tap**  
A4131AA Flexi tails  
A4169AA Copper tails



**Avon 21 push button self closing mixer tap**  
B8263AA Flexi tails  
B8861AA Copper tails



**Markwik 21+ panel mounted thermostatic mixer with time flow sensor**  
A6684AA Detachable spout



**Markwik 21+ panel mounted thermostatic basin mixer**  
A6735AA Fixed spout



**Markwik 21+ panel mounted thermostatic basin mixer**  
A6682AA Detachable spout

\*Could incur extended lead times, please contact our friendly sales team for further information

# Vepps Fittings



**Sensorflow 21 WC flush**  
S359967 4 or 4.5 litre flush



**Sensorflow 21 urinal flush**  
A7002AA High pressure link  
A7001AA High pressure mains  
A7058AA Low pressure mains\*



**Pneumatic panel mounted palm push button**  
S4513MY Stainless steel



**Conceala 2 250mm extended WC lever\***  
S4491AA



**Concentric control thermostatic shower in a box\***  
S6933MY



**Sensorflow 21 electronic shower valve and sensor\***  
A4185AA Mains  
A4186AA Link



**Avon 21 built-in self closing non-mixing shower\***  
B8266AA Chrome plated



**Anti vandal fixed shower head\***  
A5452AA

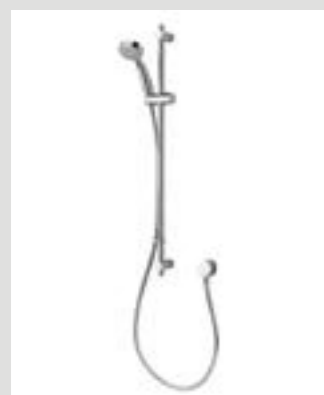

**Armaglide 2 shower kit**  
B9306AA



**Contour 21 built-in sequential shower mixer extended lever**  
A4129AA



**01 Doc M shower room pack\***  
S6960AC White  
S6960LI Blue  
S6960LJ Grey  
S6960RN Charcoal  
S6960MY Stainless Steel



**Doc M Contour 21+ back to wall left or right hand packs**  
S0685AC White - Left hand pack  
S0686AC White - Right hand pack



**Doc M Contour 21+ back to wall left or right hand packs**  
S0685LI Blue - Left hand pack  
S0686LI Blue - Right hand pack



**Doc M Contour 21+ back to wall left or right hand packs**  
S0685LJ Grey - Left hand pack  
S0686LJ Grey - Right hand pack



**Doc M Contour 21+ back to wall left or right hand packs**  
S0685MY Stainless steel - Left hand pack\*  
S0686MY Stainless steel - Right hand pack\*



**Doc M Contour 21+ back to wall left or right hand packs**  
S0685RN Charcoal - Left hand pack  
S0686RN Charcoal - Right hand pack

\*Could incur extended lead times, please contact our friendly sales team for further information

# Vepps Sanitaryware



**Langley back to wall rimless WC**  
LLWC102



**Chartham Beyond back to wall rimless WC**  
CHWC121



**Chartham back to wall WC**  
CHWC102



**Chartham rimless 450mm back to wall WC**  
CHWC103



**Shenley back to wall 350mm WC**  
SHWC101



**Chartham wall hung 700mm projection WC**  
CHWC117  
Requires Vepps WC Carrier



**Langley concealed trap urinal**  
LLUR101



**Marden concealed trap urinal**  
MDUR101



**Chartham rimless 480mm back to wall WC**  
CHWC104



**Langley wall hung rimless WC**  
LLWC101  
Requires Vepps WC Carrier



**Langley Curve wall hung WC**  
LLWC121  
Requires Vepps WC Carrier



**Chartham wall hung WC**  
CHWC101  
Requires Vepps WC Carrier



**Chartham exposed trap urinal**  
CHUR104



**Marden waterless urinal**  
MDUR103



**Chartham Beyond wall hung rimless WC**  
CHWC122  
Requires Vepps WC Carrier



**Chartham rimless back to wall 700mm projection**  
CHWC105



**Chartham rimless back to wall 750mm projection**  
CHWC106



**Langley waterless urinal**  
LLUR104



**Urinal separator**  
CHUR107



Panelling

# Vepps Sanitaryware



**Chartham 530mm countertop basin**  
CHWB112 Centre tap hole



**Langley 400mm under counter basin**  
LLWB107 No tap hole



**Shenley 500mm countertop basin**  
SHWB103 Centre tap hole  
SHWB104 2 tap holes



**Marden square semi-recessed basin 460mm**  
MDWB113 Centre tap hole



**Langley 400mm wall hung basin**  
LLWB101 Centre tap hole



**Langley semi-recessed basin 500mm**  
LLWB104 Centre tap hole



**Marden semi-recessed basin 520mm**  
MDWB105 Centre tap hole



**Chartham semi-recessed basin 450mm**  
CHWB109 Right tap hole



**Marden 525mm wall mounted basin**  
MDWB103 Centre tap hole



**Marden 420mm wall mounted basin**  
MDWB101 Centre tap hole



**Chartham semi-recessed basin 450**  
CHWB108 2 tap holes



**Shenley slim semi-recessed basin 400mm**  
SHWB105 Right tap hole



**Chartham wall hung 450mm basin**  
CHWB104 Centre tap hole



**Chartham wall hung 450mm basin**  
CHWB103 2 tap holes



**Chartham wall hung 500mm clinical back outlet basin**  
CHWB107 No tap hole

# Vepps Sanitaryware

# Vepps Brassware



**Chartham wall hung 380mm basin**  
CHWB101 Left tap hole



**Chartham wall hung 380mm basin**  
CHWB102 Right tap hole



**Marden square 460mm basin**  
MDWB111 Central tap hole



**Langley round vessel basin**  
LLWB122 No tap hole



**Langley oval vessel basin**  
LLWB123 No tap hole



**Langley rectangular vessel basin**  
LLWB121 No tap hole



**Chartham cleaners sink**  
CHSK101



**SanCeram sequential TMV3 mixer tap**  
SCBW120 Flexi tails  
SCBW115 Copper tail pack



**SanCeram basin mounted self-closing mixer tap**  
SCBW106



**Vision non-concussive self-closing mixer tap\***  
VSN123



**Insignia lever mixer tap**  
INS113



**Swoop MK2 lever mixer tap**  
SWO2113



**Swoop MK2 tall lever mixer tap**  
SWO2113EX



**Kemsley Basin mixer tap\***  
KMBW101 Chrome



**Kemsley Basin mixer tap\***  
KMBW101BB Brushed Brass



**Kemsley Basin mixer tap\***  
KMBW101MB Matt black



**Kemsley Basin mixer tap\***  
KMBW101MG Gunmetal Grey



**Kemsley Tall Basin mixer tap\***  
KMBW102 Chrome



**Kemsley Tall Basin mixer tap\***  
KMBW102BB Brushed Brass

\*Could incur extended lead times, please contact our friendly sales team for further information

# Vepps Brassware



**Kemsley Tall Basin mixer tap\***  
KMBW102MB Matt Black



**Kemsley Tall Basin mixer tap\***  
KMBW102MG Gunmetal Grey



**Deva tall sensor tap\***  
SENSOR3D



**Deva wall mounted sensor tap\***  
SENSOR9W



**Aquarius wall mounted 150mm sensor tap spout**  
AT02001



**Deva lever action bib taps**  
DLT095 Pair



**Adore mini basin mixer**  
ADORE313



**Insignia lever pillar taps**  
INS101 Pair

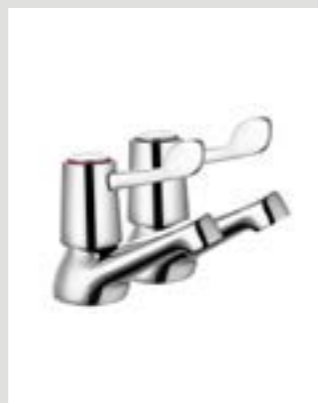

**Deva lever taps**  
VL101 Pair



**Press action taps**  
NCT001 Pair



**SanCeram healthcare TMV3 wall mounted lever tap**  
SCBW122 Removable spout  
SCBW117 HBN tap purge kit



**SanCeram healthcare TMV3 wall mounted sensor tap**  
SCBW112 Fixed spout  
SCBW117 HBN tap purge kit  
SCBW116 Mains transformer



**SanCeram healthcare TMV3 wall mounted sensor tap**  
SCBW123 Removable spout  
SCBW117 HBN tap purge kit  
SCBW116 Mains transformer

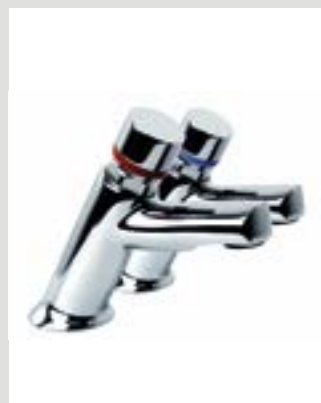

**Contemporary press action taps**  
SCBW124 Pair



**Aquarius A45 sensor tap\***  
AT03011



**SanCeram deck mounted sensor tap**  
SCBW119  
SCBW116 Mains transformer



**Deva sensor tap**  
SENSOR1D



Panelling

\*Could incur extended lead times, please contact our friendly sales team for further information

# Vepps Fittings



**Concealed WC flush sensor**  
CIST108 Single (battery)  
CIST109 Dual (battery)  
CIST110 Mains transformer



**Electroflo urinal sensor**  
URIN108 Battery  
URIN109 Mains



**Concealed dual flush cistern with square button**  
CIST104



**Concealed single flush cistern with square button**  
CIST103



**SanCeram anti-vandal short projection shower head**  
SHWR124

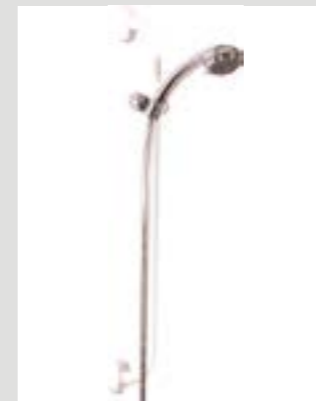

**SanCeram grab rail based shower kit**  
SHWR115 White



**SanCeram Doc M shower pack**  
SCDMSHCWH White  
SCDMSHCBL Blue

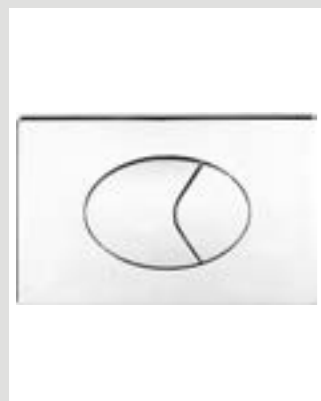

**Concealed dual flush cistern with oyster push button**  
CIST107



**Concealed single flush cistern with palm push button**  
CIST105



**Concealed single flush cistern with vandal resistant button**  
CIST106



**Concealed dual flush cistern with lever**  
CIST101



**Concealed dual flush cistern with dimple lever**  
CIST102



**Sequential lever operated concealed shower valve**  
SHWR112



**Deva Vision thermostatic concealed shower valve**  
VSNVSEQ02



**Self-closing concealed shower valve**  
SHWR122



**SanCeram back to wall WC Doc M pack**  
**Left hand pack**  
SCDMBTWLW White  
SCDMBTWLB Blue  
SCDMBTWLG Grey  
SCDMBTWLSS Stainless steel

**Right hand pack**  
SCDMBTWRW White  
SCDMBTWRB Blue  
SCDMBTWRG Grey  
SCDMBTWRSS Stainless steel

Speed.

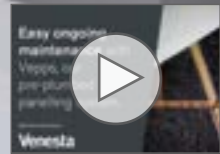

See how quick and easy it is to operate Vepps by watching our dedicated video on our YouTube channel.

**You need speedy installation.**  
Our design team created Vepps to ensure that's what you get. There are four easy steps to installation, so you can be up and running in the shortest possible time frame, with a guaranteed quality finish.

- 1** Once the site has been prepared, fix the aluminium docking frame to the wall, ceiling and floor.
- 2** Click-fix the first Vepps unit onto the frame and slide into position. Open the mid panel to a fully hinged position. Attach a vertical flashgap to the frame on either side of the unit, screw-fixing to the frame from the face. Fix tie back to the wall. Repeat until all units are in place.
- 3** Once all the units are in position, connect the plumbing and services.
- 4** Simply close the hinged panel and attach the top and bottom panels of the unit. Installation complete.

- 20 minute installation
- 30 minute installation
- 10 minute installation\*
- 5 minute installation

The comparisons given between Vepps, Frameduct and Rapiduct are a guide and are designed to help you choose the right product for your project. \*Dependent on brassware.

## Case Study ICON Outlet at The O2

Venesta were pleased to work alongside ISG and Wren Construction to provide male, female, baby and accessible washroom facilities.

Spanning an impressive 210,000 square feet, ICON Outlet is The O2's brand new urban outlet shopping centre, bringing together over 60 of the best fashion and lifestyle brands.

Unity cubicles were specified to meet the high demands of this new and exciting shopping centre. Unity's clean, modern and minimal design was the perfect choice, offering a 'floating' flush front that makes a guaranteed impact.

The HPL cubicles supplied have a durable moisture resistant chipboard core, faced with High Pressure Laminate to accommodate daily cleaning requirements. Unity also offers anti-tamper, concealed stainless steel and satin anodised aluminium fittings, ensuring the strength and security of the cubicles.

ICON Outlet selected our ground-breaking pre-plumbed Vepps system, making regular duct maintenance effortless thanks to its linear-bearing hinge. Our 90 degree hinge removes the need to manually lift off and replace panels when carrying out maintenance work, which is inefficient and could cause the panels to become damaged or misaligned.

Venesta were proud to have been involved in such a significant project, helping to ensure shoppers, diners and visitors of all ages and abilities have the best possible customer experience, even when visiting the washroom.

Read the full case study at [www.venesta.co.uk](http://www.venesta.co.uk)



# Technical Specifying Vepps

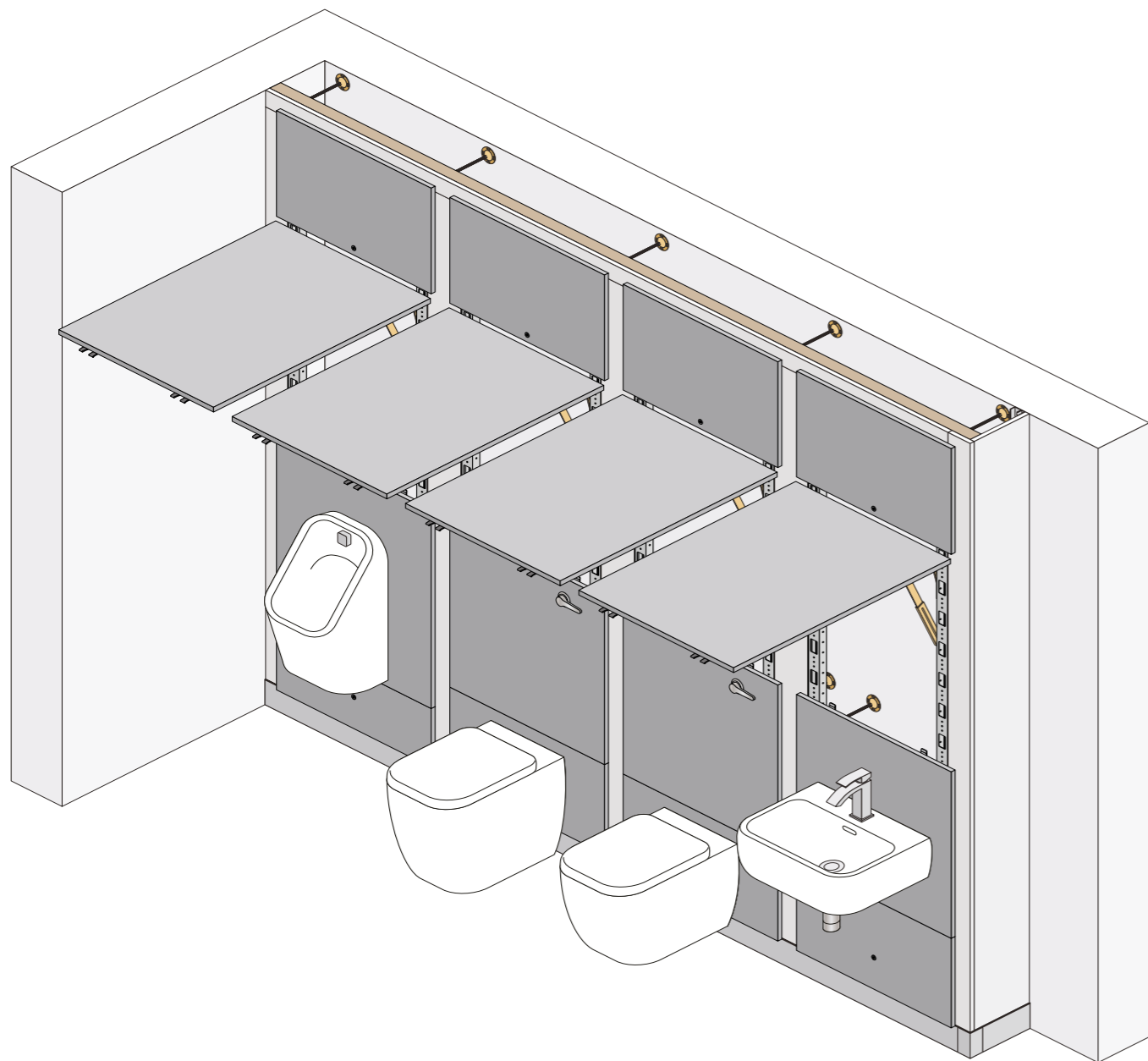

## Dimensions

### Maximum ceiling height

<b>MFC</b>	3000mm
<b>HPL</b>	3000mm
<b>SGL</b>	3000mm

Maximum heights subject to change with woodgrain colours.

Bespoke heights available.

### Skirting/baserail height

100mm

### Top flashgap

50mm minimum

### Hinged panels

Hinged and lockable panels available up to 850mm width.

## Sanitaryware



Fitted sanitaryware has been specially engineered to give you the highest quality finish.

### WCs

### Basins

### Urinals

### Showers

### Washtroughs

### Baths

### Squat pans

### Cleaners sinks

### Healthcare items

## Performance

Available in six material options, Vepps is suitable for every type of wet or dry environment, allowing you to specify the most appropriate panel option to meet the site requirements and your budget.

### MFC

For dry environments with low risk of vandalism. Panels are manufactured from 19mm nominal thickness high performance moisture-resistant Melamine Faced Chipboard. Edges with matching lipping.

### HPL

For more heavily used washrooms, panels are heat, scratch and impact resistant. Manufactured from moisture-resistant chipboard faced with High Pressure Laminate, panels are 19mm nominal thickness. Edges with matching lipping. Post-formed vertical edge option available.

### SGL

Solid grade laminate is extremely resistant to impact and all surfaces are impervious to water. Panels are 13mm nominal thickness with polished black radiused edges.

### ColourCoat

Panels are 18mm nominal thickness MDF sprayed with a coat of primer and finished with 20% gloss pigmented lacquer.

### ColourCoat High Gloss

Panels are 18mm nominal thickness MDF sprayed with a coat of primer and finished with 80% gloss pigmented lacquer.

### Veneer

Manufactured from moisture resistant chipboard faced with real wood veneer, panels are 18mm nominal thickness. Edges with matching lipping.

## Detailing

### Panels

Available in MFC, HPL, SGL, ColourCoat, ColourCoat High Gloss and Veneer.

### Flashgaps

MFC, SGL, ColourCoat, ColourCoat High Gloss and Veneer.

### Colour finish

#### MFC, HPL and SGL

34 colours.

#### ColourCoat & ColourCoat High Gloss

10 ColourCoat and ColourCoat High Gloss colours available when specifying Vepps with selected V1 and V2 cubicle ranges. Unlimited ColourCoat and ColourCoat High Gloss options (any classic RAL) when specifying Vepps with selected V3 cubicle ranges.

#### Veneer

Wide range of Alpi veneer options (varying price points).

### Edge treatment

#### MFC and HPL

Matching lipping.

Post-formed vertical edge option available with HPL.

#### SGL

Polished black radiused edge.

#### ColourCoat & ColourCoat High Gloss

Edges are sprayed with a coat of primer and finished with 20% or 80% gloss pigmented lacquer, respectively.

#### Veneer

Matching lipping.

#### Flashgaps

Flashgaps have unfinished edges except return end flashgaps which will be matching lipping (or polished if Solid Grade Laminate).

### Docking frame

Headrail and baserail manufactured from extruded aluminium section.

### Subframes

Manufactured from rolled galvanised steel section with aluminium cross brace bars. Subframe installed within aluminium docking frame by click-fix nylon location brackets. Back panels fixed to steel section by metal brackets.

### 90° linear-bearing hinge™

Manufactured from zinc plated steel with chrome plated rivets and black glass filled nylon linear-bearing, set at fixed height of 1950mm.

### Panel lock

Manufactured from stainless steel with a polished finish in set positions.

## Technical Specifying Vepps

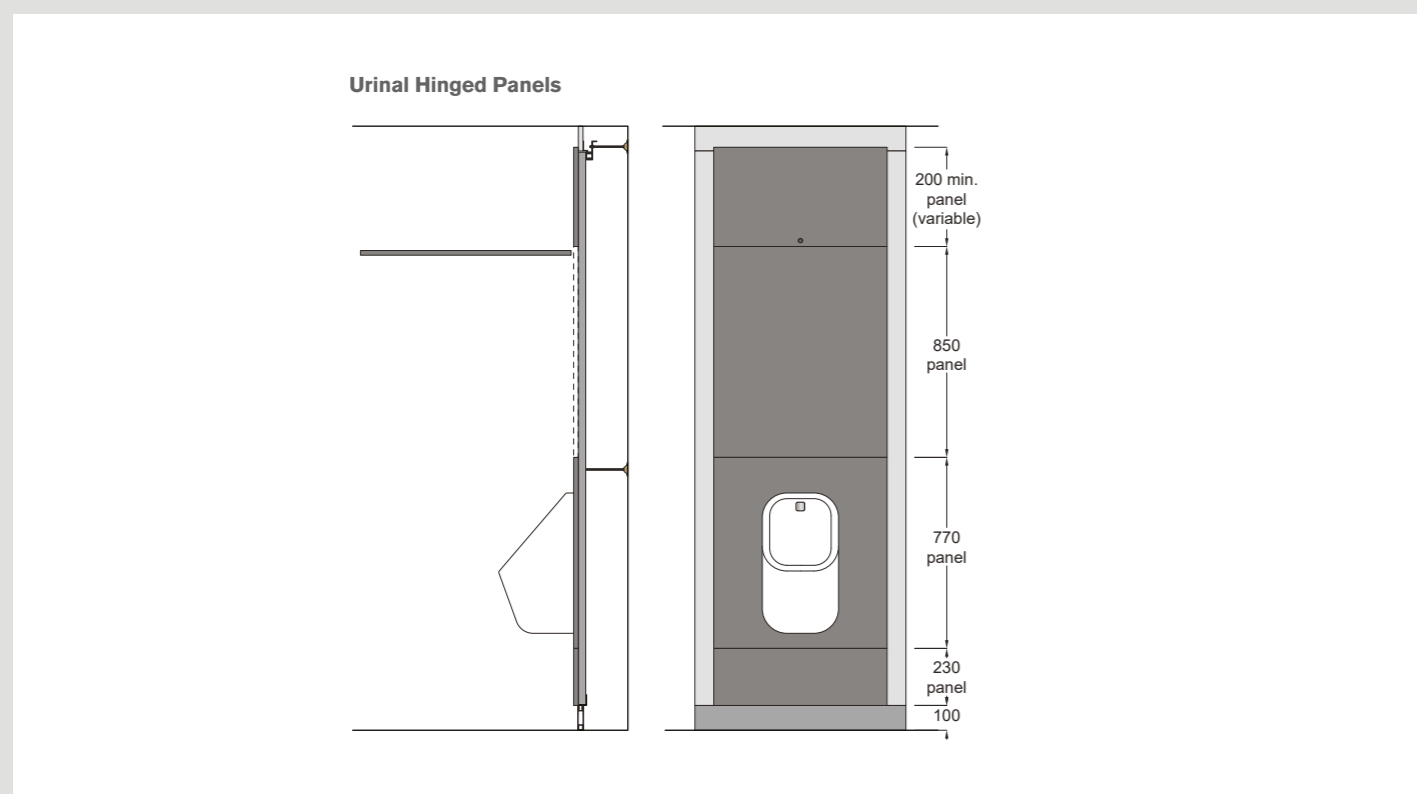
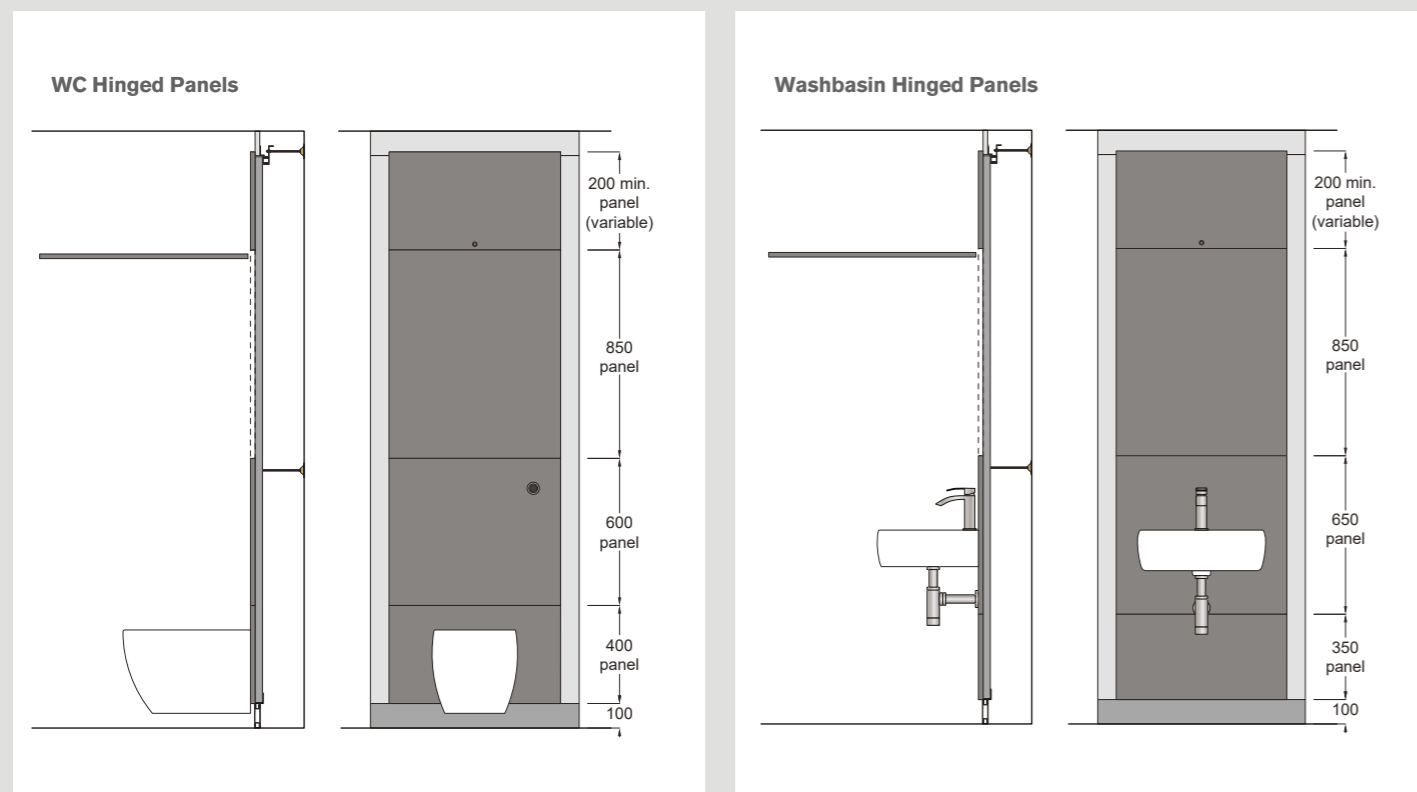

## Secrets of Vepps

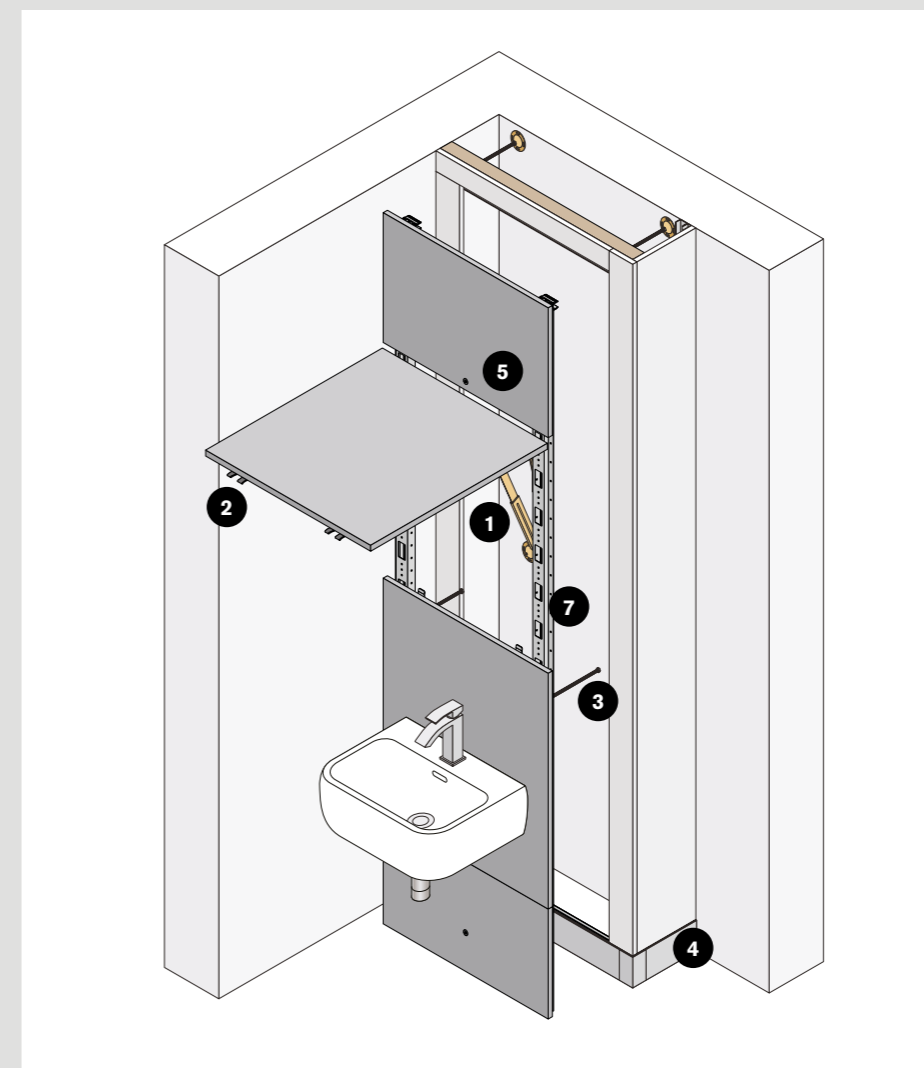

**1. Venesta linear-bearing hinge™**  
Our precision engineered, high strength linear-bearing hinges and panel support ratchets offer smooth movement and allow panels to be positioned at 10 different heights, all without any gaps between panels. Patent approved.

**2. Venesta dowel-dock**  
Designed for strength and perfect panel alignment, our dowel-dock system ensures panels return to their correct position every time. Patent approved.

**3. Tie backs**  
Adjustable zinc plated steel tie backs offer a bracing system for improved stability and allow for easier, speedier installation.

**4. Baserail**  
Designed in a smooth, modern Light Grey or Dark Grey powder coated aluminium finish, the Vepps baserail, ensures compatibility with all cubicle ranges and washroom designs.

**5. Panel lock**  
We understand the need for added safety without compromised aesthetics. In stainless steel with a tamper proof security key opening, our panel locks are discreet and ensure maximum security.

**6. Wall hung WC carrier**  
Our wall hung WC carrier is made from Solid Grade Laminate. It simply locates into the baserail and is fixed back to the building structure without the need for floor bolts. The assembly has been load tested to 400kg and complies with BSEN 997.

**7. Fittings**  
We understand the need for products that last. That's why all of our metal components are non-ferrous or coated to protect against rusting and corrosion.

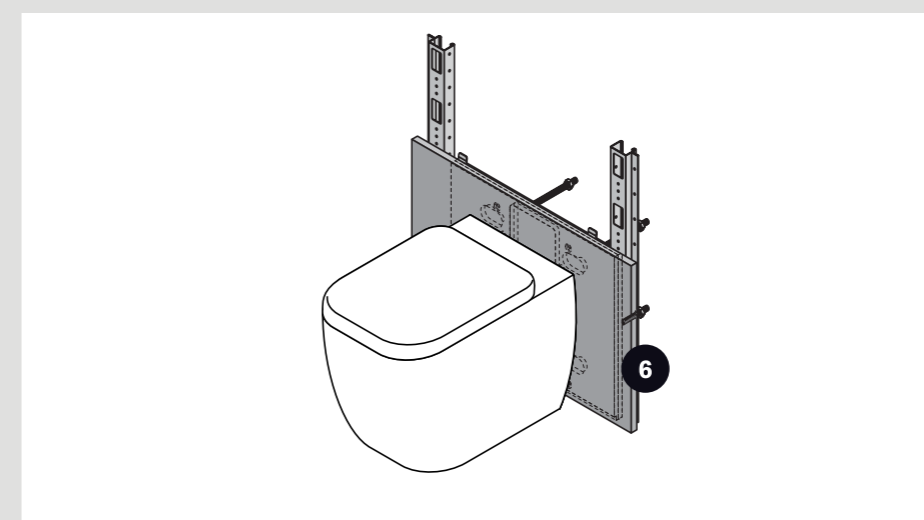

**Frameduct** is our made to measure, ready to install metal-framed non-plumbed system. It has all the cutting edge features you need but gives you the flexibility to choose your own sanitaryware.

frameduct

## Frameduct Easy installation

Frameduct's superbly crafted, metal-framed panelling has been created to give you quick and easy installation. Its clever click-fix mechanism is simplicity itself. Not only that, Frameduct gives you the opportunity to choose your own sanitaryware.



**01** Once the site has been prepared, fix the aluminium docking frame to the wall, ceiling and floor.

20 minute installation



**02** Click-fix the first Frameduct unit onto the frame and slide into position. Open the mid panel to a fully hinged position. Attach a vertical flashgap to the frame on either side of the unit, screw-fixing to the frame from the face. Fix tie back to the wall. Repeat until all units are in place.

30 minute installation



**03** Drill or cut out for sanitaryware.

10 minute installation

## You need easy installation.

Frameduct brings you an intelligent, great looking system that's easy to install but with an added bonus - you get to choose your own sanitaryware.



**04** Mount sanitaryware and brassware.

20 minute installation



**05** Once all the units are in position, connect the plumbing and services and apply silicone sealant to sanitaryware.

10 minute installation\*

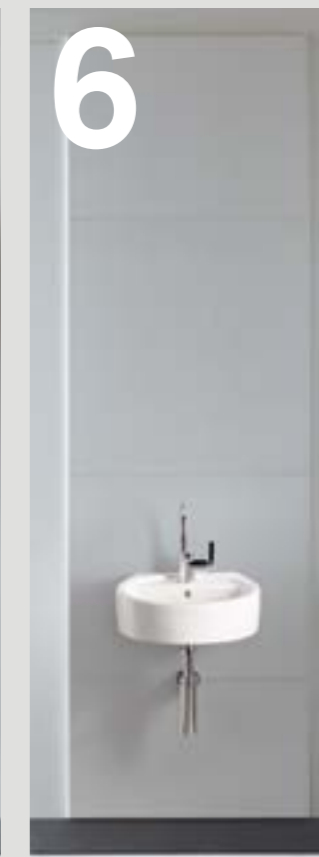

**06** Simply close the hinged panel and attach the top and bottom panels of the units. Installation is complete.

5 minute installation

# Technical Specifying Frameduct

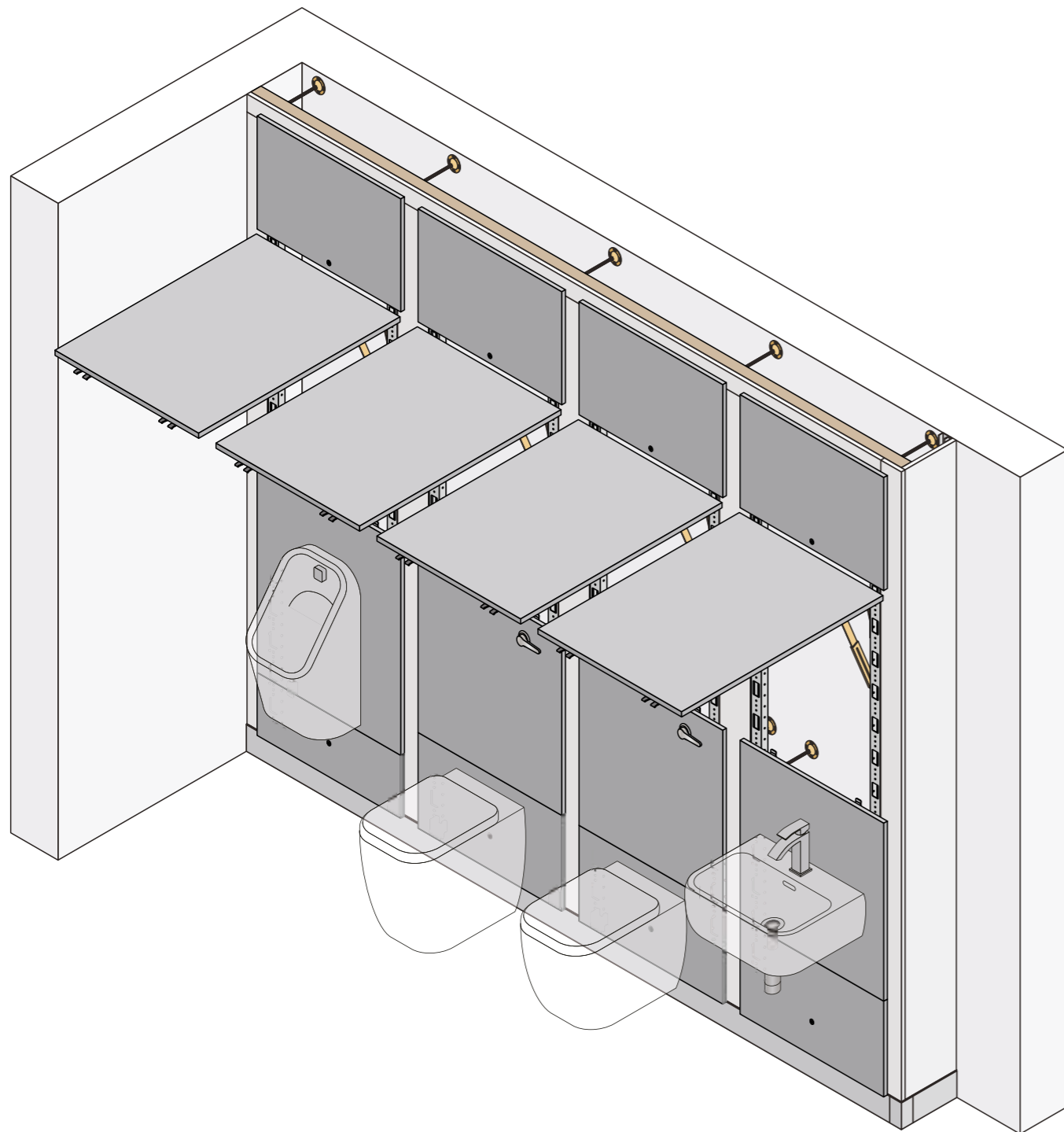

## Dimensions

### Maximum ceiling height\*

<b>MFC</b>	3000mm
<b>HPL</b>	3000mm
<b>SGL</b>	3000mm

\*Maximum heights subject to change with woodgrain colours.

Bespoke heights available.

### Skirting/baserail height

100mm (other skirting heights achievable by site packing the baserail).

### Top flashgap

50mm

### Hinged Panels

Hinged and lockable panels available up to 850mm width.

## Performance

Available in six material options, Frameduct is suitable for every type of wet or dry environment allowing you to specify the most appropriate panel option to meet the site requirements and your budget.

### MFC

For dry environments with low risk of vandalism. Panels are manufactured from 19mm nominal thickness high performance moisture-resistant Melamine Faced Chipboard. Edges with matching lipping.

### HPL

For more heavily used washrooms, panels are heat, scratch and impact resistant. Manufactured from moisture-resistant chipboard faced with High Pressure Laminate, panels are 19mm nominal thickness. Edges with matching lipping. Post-formed vertical edge option available.

### SGL

Solid Grade Laminate is extremely resistant to impact and all surfaces are impervious to water. Panels are 13mm nominal thickness with polished black radiused edges.

### ColourCoat

Panels are 19mm nominal thickness MDF finished, sprayed with a coat of primer and finished with 20% gloss pigmented lacquer.

### ColourCoat High Gloss

Panels are 18mm nominal thickness MDF finished, sprayed with a coat of primer and finished with 80% gloss pigmented lacquer.

### Veneer

Manufactured from moisture resistant chipboard faced with real wood veneer, panels are 18mm nominal thickness. Edges with matching lipping.

## Detailing

### Panels

Available in MFC, HPL, SGL, ColourCoat, ColourCoat High Gloss and Veneer.

### Flashgaps

MFC, SGL, ColourCoat, ColourCoat High Gloss and Veneer.

### Colour finish

**MFC, HPL and SGL**

34 colours.

**ColourCoat and ColourCoat High Gloss**

10 ColourCoat and ColourCoat High Gloss colours available when specifying Frameduct with selected V1 and V2 cubicle ranges.

Unlimited ColourCoat and ColourCoat High Gloss options (any classic RAL) when specifying Frameduct with selected V3 cubicle ranges.

**Veneer**

Wide range of Alpi veneer options (varying price points).

### Edge treatment

**MFC and HPL**

Matching lipping.

Post-formed vertical edge option available with HPL.

**SGL**

Polished black radiused edge.

**ColourCoat and ColourCoat High Gloss**

Edges are sprayed with a coat of primer and finished with 20% or 80% gloss pigmented lacquer, respectively.

**Veneer**

ABS lipping to match.

**Flashgaps**

Flashgaps have unfinished edges except return end flashgaps which will be matching lipping (or polished if Solid Grade Laminate).

### Docking frame

Headrail and baserail manufactured from extruded aluminium section.

### Subframes

Manufactured from rolled galvanised steel section with aluminium cross brace bars. Subframe installed within aluminium docking frame by click-fix nylon location brackets. Back panels fixed to steel section by nylon clips.

### 90° linear-bearing hinge™

Manufactured from zinc plated steel with chrome plated rivets and black glass filled nylon linear-bearing, set at fixed height of 1950mm.

### Panel lock

Manufactured from stainless steel with a polished finish in set positions.

**Rapiduct** is a low-cost bespoke duct panelling system specially created by our panelling experts to give you easy installation and a functional finish, perfect for any wet or dry washroom environment.

Rapiduct

## Rapiduct Easy installation

The best value for function, finish and easy installation, Rapiduct's clever construction means it can be put together in the shortest time.



**01** Install timber-frame (supplied by others).

30 minute installation

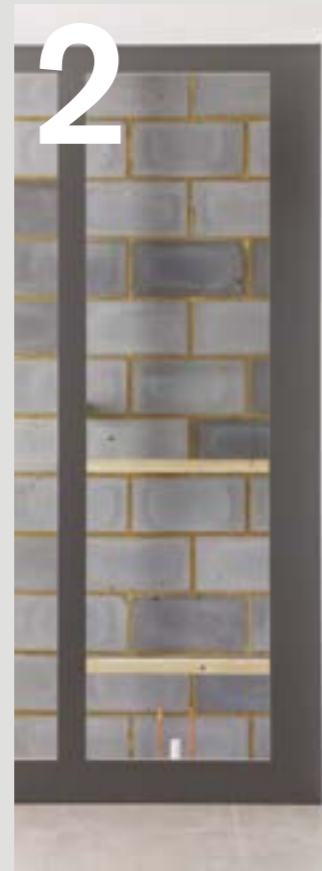

**02** Fit base flashgaps to the site frame followed by vertical, horizontal and top flashgaps.

20 minute installation

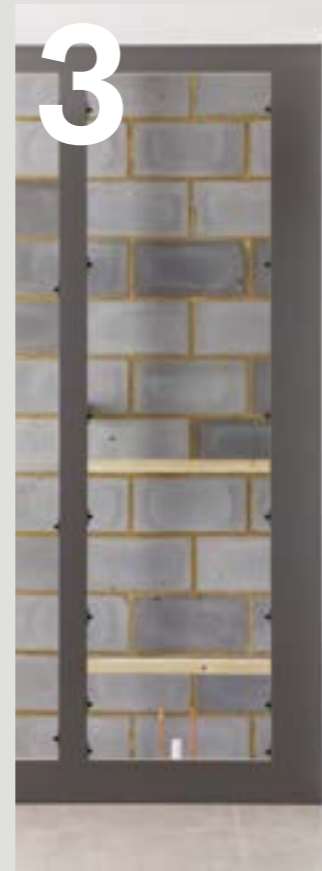

**03** Attach fixing clips to the inside edge of the vertical flashgaps, repeat process on back face of panels.

30 minute installation

## You need easy installation.

Simple, functional and highly cost-effective, this timber-framed panelling system is flexible enough to suit any washroom and is designed for your own installation. You can specify Rapiduct with any Venesta cubicle or vanity system.



**04** Drill or cut out for sanitaryware.

10 minute installation

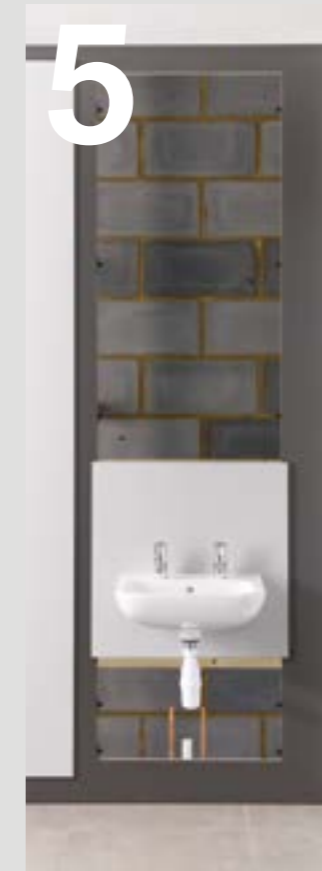

**05** Mount combined panel, sanitaryware and brassware onto flashgaps before completing pipework.

20 minute installation

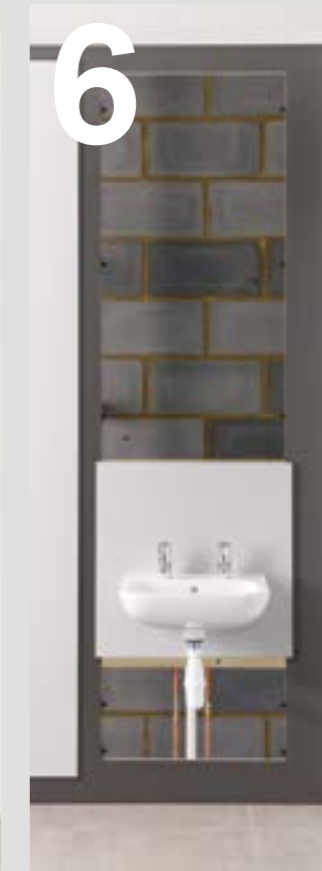

**06** Once all the units are in position, connect the plumbing and services.

10 minute installation\*

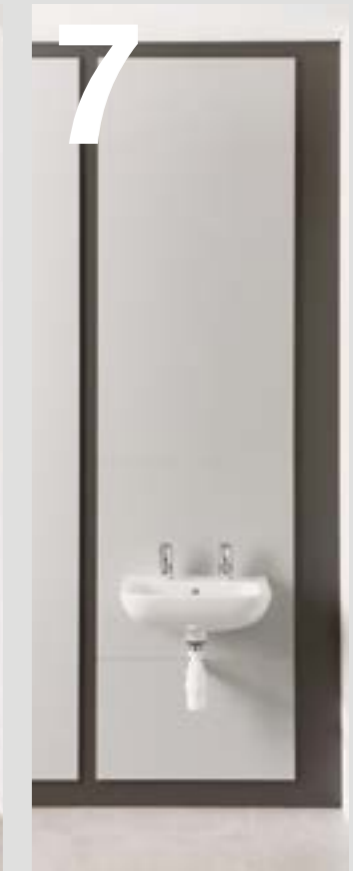

**07** Simply attach the top and bottom panels to the units. Installation complete.

5 minute installation

# Technical Specifying Rapiduct

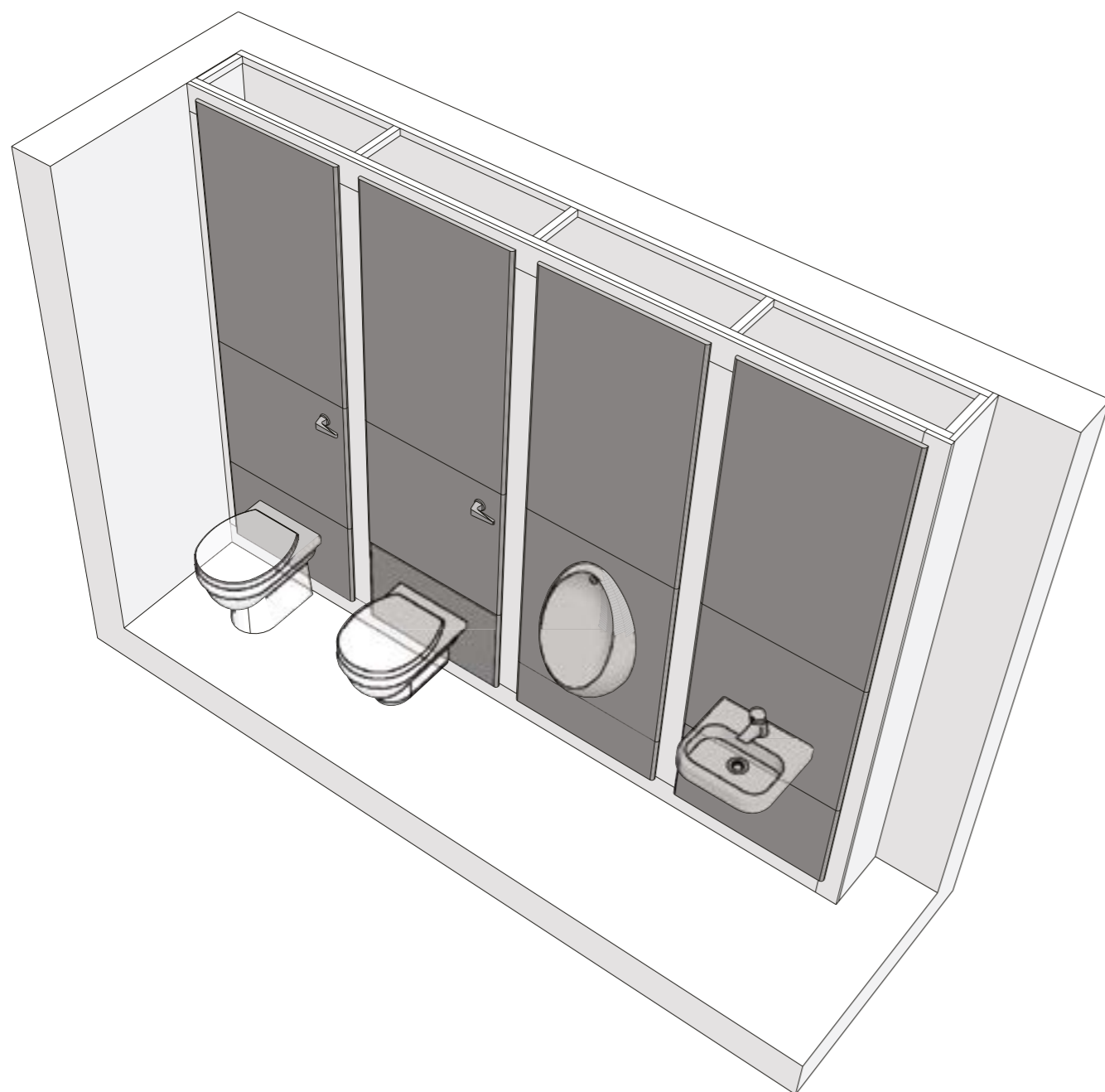

## Dimensions

Bespoke panel sizes available to suit site dimensions.

## Performance

Available in six material options, Rapiduct is suitable for every type of wet or dry environment, allowing you to specify the most appropriate panel option to meet the site requirements and your budget.

### MFC

For dry environments with low risk of vandalism. Panels are manufactured from 19mm nominal thickness high performance moisture-resistant Melamine Faced Chipboard. Edges with matching lipping.

### HPL

For more heavily used washrooms, panels are heat, scratch and impact resistant. Manufactured from moisture-resistant chipboard faced with High Pressure Laminate, panels are 19mm nominal thickness. Edges with matching lipping. Post-formed vertical edge option available.

### SGL

Solid Grade Laminate is extremely resistant to impact and all surfaces are impervious to water. Panels are 13mm nominal thickness with polished black radiused edges.

### ColourCoat

Panels are 18mm nominal thickness MDF finished, sprayed with a coat of primer and finished with 20% gloss pigmented lacquer.

### ColourCoat High Gloss

Panels are 18mm nominal thickness MDF finished, sprayed with a coat of primer and finished with 80% gloss pigmented lacquer.

### Veneer

Manufactured from chipboard faced with real wood veneer, panels are 18mm nominal thickness. Edges with matching lipping.

## Detailing

### Panels

Available in MFC, HPL, SGL, ColourCoat, ColourCoat High Gloss and Veneer.

### Flashgaps

MFC, SGL, ColourCoat, ColourCoat High Gloss and Veneer.

### Colour finish

#### MFC, HPL and SGL

34 colours.

#### ColourCoat and ColourCoat High Gloss

10 ColourCoat and ColourCoat High Gloss options available when specifying Rapiduct with a V2 cubicle range.

Unlimited ColourCoat and ColourCoat High Gloss options (any classic RAL) when specifying Rapiduct with a V3 cubicle range.

#### Veneer

Wide range of Alpi veneer options (varying price points).

### Edge treatment

#### MFC and HPL

Matching lipping.

#### SGL

Polished black radiused edge.

#### ColourCoat and ColourCoat High Gloss

Edges are sprayed with a coat of primer and finished with 20% or 80% gloss pigmented lacquer, respectively.

#### Veneer

Matching lipping.

#### Flashgaps

Flashgaps have unfinished edges except return end flashgaps which will be matching lipping. (or polished if Solid Grade Laminate).

### Fixing clips

Concealed plastic clips fixed to edge of flashgap strips and reverse of facing panels.

### Site frame

Loose flashgaps only supplied by Venesta. Site frame supplied and fixed by site (softwood or similar).

**We know Mirror Box Units, vanities and accessories.**

To meet your demands, our range of Mirror Box Units, vanities and accessories bring form and function together in one collection.

**Mirrors, vanities and accessories**

Our **Mirror Box Units** combine contemporary style with convenient storage for a modern, minimalist solution suitable for all kinds of commercial washrooms.

# Mirror Box Units



# Mirror Box Unit

A minimalist design illuminated by halo back-lit and front facing LEDs, guaranteed to make a bold statement. The lockable mirrors combine functional concealed contactless accessories with additional storage space, maximising available wall space and eliminating the requirement for wall hung accessories.



01

**01** Fully concealed water outlets, soap dispensers and hand dryers with back-lit etched icons.

**02** Experience improved commercial washroom hygiene with touchless accessories, all assembled off-site for speedy installation.

See p222-223 for Mirror Box Unit technical specifications.

### Main image

1300mm Mirror Box Units with integrated water outlets, soap dispensers and hand dryers, with yellow hue halo back lighting and etched icons. WT6 profile Solid Surface washtrough in Alabaster.

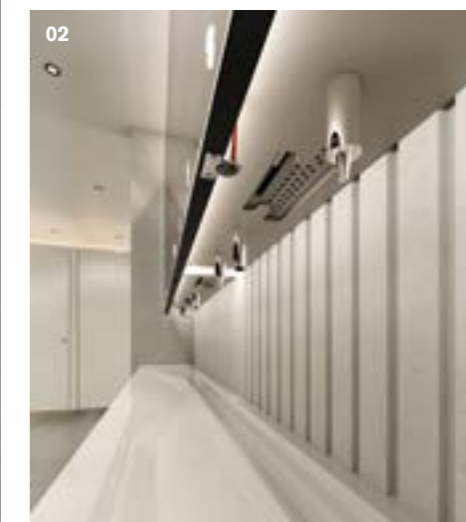

02

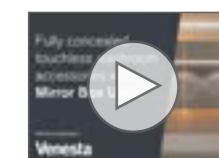

Visit our YouTube channel to explore the features and benefits of Mirror Box Units.

### Key features

- Minimalist design available in widths between 500mm and 1300mm to suit your brief
- Illuminated by halo back-lit and front facing LEDs in a choice of over 16 million colour combinations
- Fully concealed behind mirror water outlets, hand dryers, liquid soap and hand sanitiser dispensers, plus paper towel dispensers
- Carcass and accessories are off-site assembled for speedy installation
- Increased levels of hygiene with contactless technology and easy to clean surfaces
- Mirror door manufactured from SGL for enhanced strength and impact resistance

## Mirror Box Unit

Mirror Box Units are available with a range of configurable accessories and layouts to suit your requirements. Choose from contactless water outlets, liquid hand soap and sanitiser dispensers, automatic hand dryers and paper towel dispensers. Accessories are concealed to keep surfaces clear, hygienic and easy to clean, with easy ongoing maintenance.



**01** A 500mm wide Mirror Box Unit with soap dispenser and hand dryer, with blue LED lighting.

**02** Fully concealed and touchless soap dispenser and hand dryer, with etched accessory icons for added durability.

See p222-223 for Mirror Box Unit technical specifications.

### Main image

700mm Mirror Box Units with integrated hand sanitiser outlets, soap and paper towel dispensers, with cool white halo and front facing lights. Q5 profile Quartz vanity in Nickel with Langley oval vessel basins and Deva tall sensor taps.



### Key features

- Illuminated by back-lit and front facing LEDs to offer design flexibility with a choice of over 16 million colour combinations
- Speedy installation with carcass and accessories pre-assembled
- Touch free fully concealed washroom accessories
- Customisable accessory configuration to meet requirements
- Accessory icons can be etched into the glass for added durability and visual impact when lit
- Convenient storage with internal shelf
- Easy operational plunge locks as standard, secured directly into the carcass

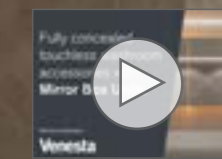

Take a closer look at Mirror Box Units by watching the dedicated video on our YouTube channel.

# Technical Specifying Mirror Box Units

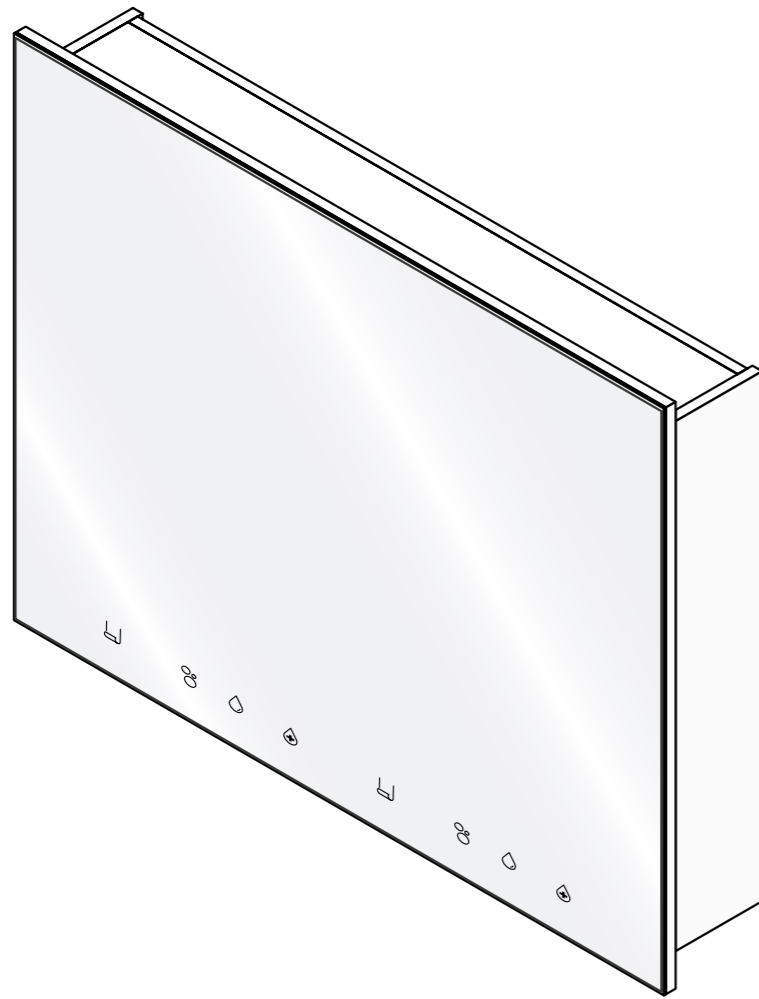

## Width options

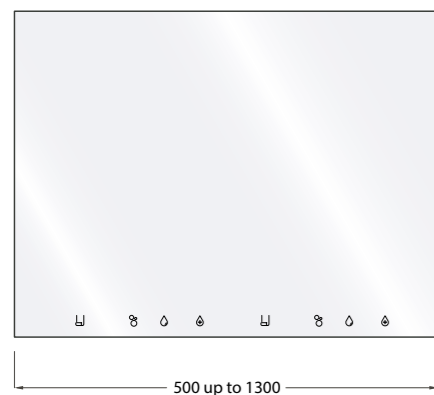

## Activity space

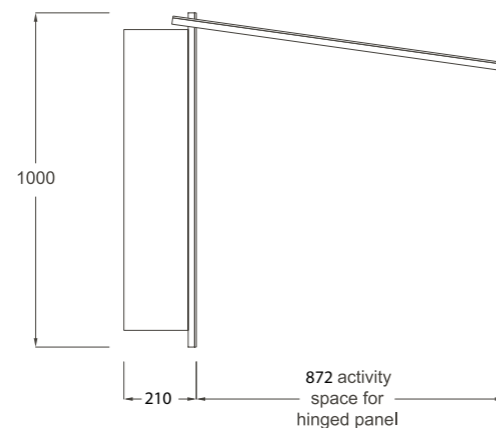

## Dimensions

### Height

1000mm

### Width

Available in 5mm increments from 500mm up to a maximum of 1300mm

### Depth

210mm

### Mounting spaces

From 2 up to 12 mounting spaces

### Hinged panel

872mm activity space

## Performance

### HPL

Mirror Box Unit carcass manufactured from 19mm nominal thickness moisture resistant High Pressure Laminate (HPL). Edges with matching lipping.

### SGL

Mirror door and decorative end panels manufactured from 13mm nominal thickness Solid Grade Laminate.

### Glass

4mm thick silver safety back mirror with polished edges.

## Detailing

### Carcass

High performance moisture-resistant High Pressure Laminate.

### Colour finish

Carcass

Porcelain.

Glass

Silver back mirror.

### Edge treatment

HPL

Matching lipping.

SGL

Polished black radiused edge.

Glass

Polished edges.

### Hardware

Hinges

Door fitted with gas strut hinges.

Lock

Mounted plunge lock.

Lighting

Supplied with cool white 6000k LED lighting as standard, or optional 4000k RGBW LED lighting in 16 million colour variations. These are fitted flush into a rebate on rear of the door, providing a bright back-lit halo around the unit, or as front-facing vanity lighting. Installed using waterproof IP67 rated connectors, with average lifespan of 50,000 hours.

Fixings

Supplied with Z-hangers for wall/panel fixings. Fixing kit for hard wall installations. Other wall or board types will require a suitable fixing kit.

### Accessories\*

Water dispenser

Automatic hand sensor, available with or without hot and cold blending valve. Pressure-tested with a visible outlet for easy positioning. Requires 100mm of space.

Liquid soap dispenser

Mains powered as standard, automatic hand sensor. 1L liquid soap capacity equivalent to 1,600 dispenses. Requires 100mm of space.

Hand sanitiser dispenser

Mains powered as standard, automatic hand sensor. 1L hand sanitiser capacity equivalent to 1,600 dispenses. Requires 100mm of space.

Hand dryer

Automatic hand sensor, 75 dBA noise rating, 85 m/s capacity, 900W motor, mains feed required into rear of unit. Requires 300mm of space.

Paper towel dispenser

Suitable for most standard multi-fold paper towels, capable of holding three stacks of paper towels. Top loading by access inside cabinet. Requires 300mm of space.

\*All accessory icon indicators available as standard or with optional etching.

We've created a **vanities** collection that's contemporary in style and highly functional. Whether you're looking to create a prestigious, luxury finish or something simple and understated, our collection has everything you need.

# Vanities

# Vanities Quartz





Dramatic and durable - that's quartz. This natural finish vanity surface combines the high-class look and feel of natural quartz with a resin composite for maximum durability. In short, a fabulous choice for maximum impact.

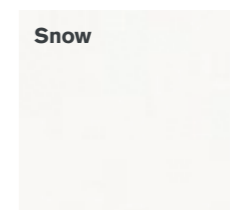
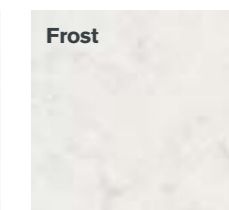

### Key features

- Natural quartz with resin composite for maximum durability
- Stunning visual impact
- A choice of nine on-trend finishes
- Available with complementary basins and cantilever support brackets
- Resistant to heat and scratching
- Non-porous surface

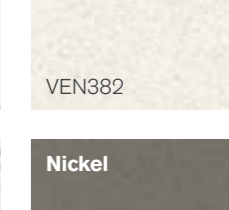
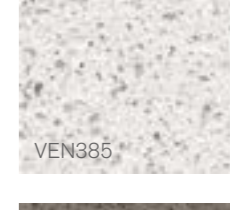
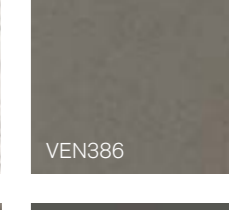
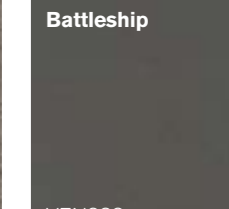

<p><b>Snow</b></p>  <p>VEN381</p>	<p><b>Frost</b></p>  <p>VEN384</p>
<p><b>Dolomite</b></p>  <p>VEN383</p>	<p><b>Nougat</b></p>  <p>VEN382</p>
<p><b>Luna</b></p>  <p>VEN385</p>	<p><b>Nickel</b></p>  <p>VEN386</p>
<p><b>Carbon</b></p>  <p>VEN387</p>	<p><b>Battleship</b></p>  <p>VEN388</p>
	<p><b>Jet</b></p>  <p>VEN389</p>

**01** Quartz vanity in Snow with Langley round vessel basins and Hartley tall basin mixer taps in brushed nickel.

**02** Quartz vanity with Marlow basins and Jasper Morrison mixer taps.

**Main image**  
Quartz vanity with bespoke downstand. White vessel basin and silver wall mounted mixer taps.

To view the range of quartz vanity profiles please turn to p235

# Vanities Solid Surface

For luxury, strength and a smooth, seamless finish, our Solid Surface solution wins hands down. The carefully composed blend of acrylic polymer minerals and integral moulded reinforcements create a low maintenance, non-porous material which ensures complete impact and thermal shock resistance. Now available in 13 striking profiles and in a choice of 22 on-trend finishes, for ultimate washroom design flexibility.



**Key features**

- Sleek, solid material ensures consistency and durability
- 13 vanity profiles, including stylish washtroughs, all in a choice of 22 on-trend finishes
- A choice of thermoformed or hidden waste washtroughs
- Integral bowl option offers a seamless finish
- Offers flexibility and space efficiency
- A non-porous material that resists stains and bacteria
- Impact-resistant and requires very little maintenance

To view the range of Solid Surface washtrough and vanity profiles, please see p234.



<b>Alabaster</b> VEN403	<b>Limestone<sup>†</sup></b> VEN413	<b>Chalk</b> VEN404
<b>Roman Marble<sup>†</sup></b> VEN418	<b>Crystal<sup>†</sup></b> VEN419	<b>Grey Topaz</b> VEN408
<b>Travertine<sup>†</sup></b> VEN414	<b>Pumice</b> VEN401	<b>Pewter</b> VEN411
<b>Natrolite<sup>†</sup></b> VEN417	<b>Calcite</b> VEN406	<b>Lollingite</b> VEN407
<b>Merlinite<sup>†</sup></b> VEN415	<b>Dravite</b> VEN412	<b>Hematite</b> VEN402
<b>Garnet<sup>†</sup></b> VEN421	<b>Volcanic<sup>†</sup></b> VEN420	<b>Neptunite<sup>†</sup></b> VEN416
<b>Galaxyite</b> VEN405	<b>Slate<sup>†</sup></b> VEN422	
<b>Citrine</b> VEN409	<b>Jade</b> VEN410	

**01** Solid Surface vanity with Concept Sphere vessel basins and silver monoblock mixer taps.

**02** Solid Surface vanity with Concept Sphere semi-recessed basins and silver dual lever monoblock mixer taps.

**Main image**  
Solid Surface hidden waste WT6 profile washtrough in Limestone with American Black Walnut Straight Grain veneer underpanels, Deva wall mounted sensor taps and 700mm Mirror Box Units.

<sup>†</sup>The marked Solid Surface finishes have varying price points. Please consult our sales team on 01474 353333 for further information.

## Vanities SGL

The most demanding washroom environments need durable and hard-working solutions to match. Solid Grade Laminate (SGL) is built to last and is totally impervious to water. Plus, it comes in a choice of 34 on-trend colours.



### Key features

Hard-working 13mm nominal thickness SGL

Ultimate performance for demanding environments

Totally impervious to water

Suitable for wet and dry environments

Curved aluminium extrusions provide a smooth finish to the vanity upstand and downstand

Available in 34 colour options

A choice of vanity profiles

**01** SGL vanity with Orbit basins and Avon pillar taps.

**Main image**  
SGL vanity with Concept Sphere semi-recessed basins and Avon 21 mixer taps.



To view the range of SGL vanity profiles please turn to p235.

## Vanities HPL

High Pressure Laminate (HPL) is highly economical, delivering top marks on finish and design and a superb choice for any dry environment. Ensuring maximum choice, it comes with a selection of vanity profiles and in a choice of 34 colours.



### Key features

An ideal solution for any dry environment  
Quality manufacturing and design at an economical price  
Available in 34 colour options  
Choice of vanity profiles

To view the range of HPL vanity profiles please turn to p235.



01

**01** Lollipop HPL vanity in Olive, Peony and Soft Oak with Sandringham 21 semi-recessed basins and Sandringham 21 self closing pillar taps.

**02** Baby change unit with Orbit basins and Tratto lever monoblock taps.

### Main image

HPL vanity with Orbit basins and Sensorflow 21 taps.



02

### Key features

Anti-roll front upstand  
Quality manufacturing and design at an economical price  
Available in 34 colour options

# Technical Specifying Vanities

## Solid Surface Washtrough

13mm blend of acrylic polymer minerals with integral moulded-in-reinforcements that provide impact and thermal shock resistance. Suitable for heavy duty applications. Maximum single Solid Surface vanity unit length is 3000mm. Any stud framework is by site.

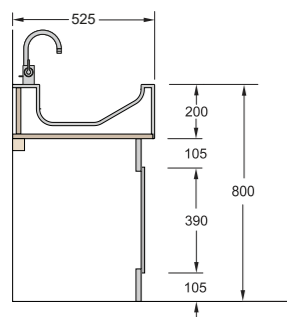

**WT1 Thermo Profile**  
Thermoformed trough with deck mounted taps. A choice of underframe or brackets.

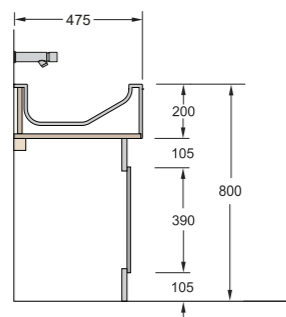

**WT2 Thermo Profile**  
Thermoformed trough with wall mounted taps. A choice of underframe or brackets.

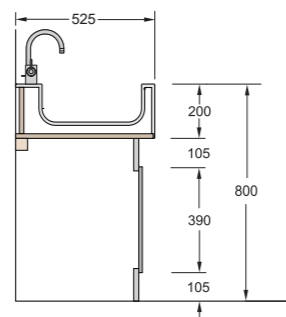

**WT3 Thermo Profile**  
Thermoformed trough with deck mounted taps. A choice of underframe or brackets.

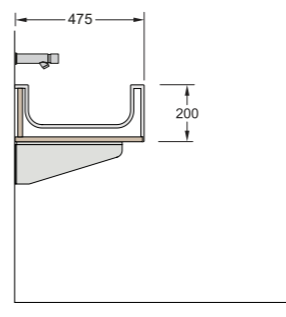

**WT4 Thermo Profile**  
Thermoformed trough with wall mounted taps. A choice of brackets or underframe.

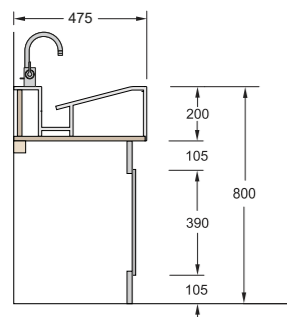

**WT5 Profile**  
Concealed waste trough with deck mounted taps. A choice of underframe or brackets.

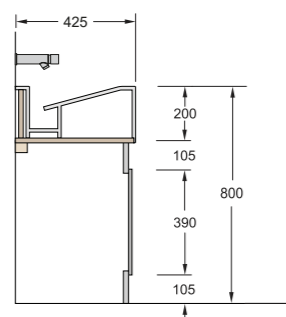

**WT6 Profile**  
Concealed waste trough with wall mounted taps. A choice of underframe or brackets.

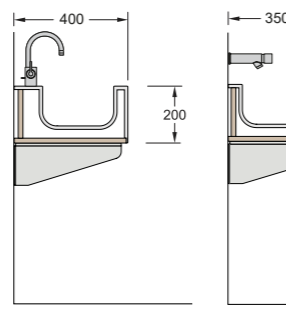

**WT3 Thermo Slim Profile**  
Slim thermoformed trough with deck mounted taps. A choice of brackets or underframe.

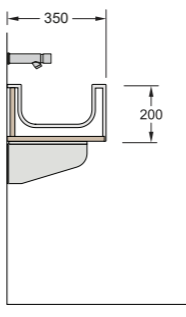

**WT4 Thermo Slim Profile**  
Slim thermoformed trough with wall mounted taps. A choice of brackets or underframe.

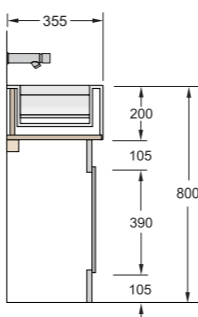

**MyPod Profile**  
Slim concealed waste trough with wall mounted taps. A choice of underframe or brackets.

## Education Solid Surface Washtrough

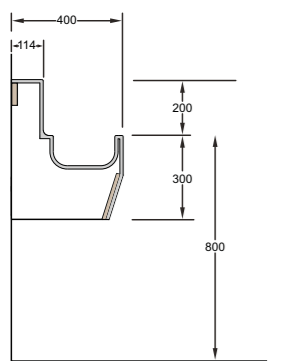

**DfE1 Thermo Profile**  
Thermoformed trough with wall mounted taps. A choice of underframe or brackets.

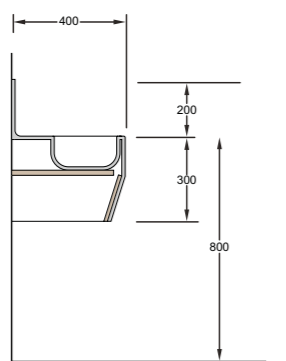

**DfE2 Thermo Profile**  
Thermoformed trough with deck mounted taps. A choice of underframe or brackets.

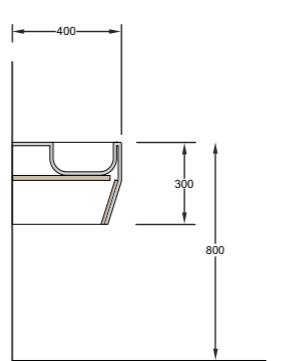

**DfE3 Thermo Profile**  
Thermoformed trough with deck mounted taps. A choice of underframe or brackets.

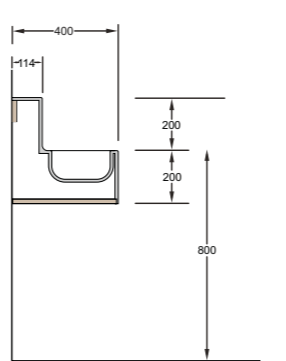

**DfE4 Thermo Profile**  
Thermoformed trough with wall mounted taps. A choice of brackets or underframe.

## Solid Surface

Solid Surface vanity unit length is 3000mm.

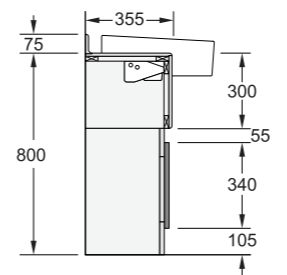

**H1 Profile**  
Semi-recessed basin with upstand.

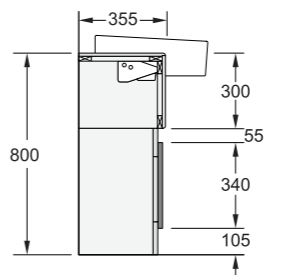

**H2 Profile**  
Semi-recessed basin without upstand.

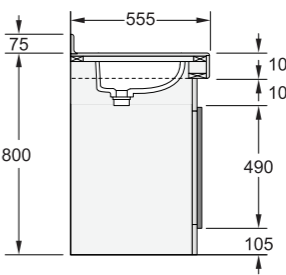

**H3 Profile**  
Fully inset basin with upstand.

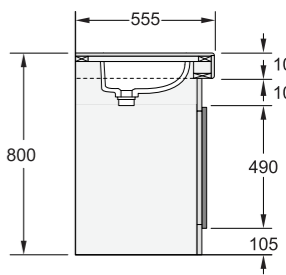

**H4 Profile**  
Fully inset basin without upstand.

## HPL

For light and medium duty applications. High performance moisture resistant chipboard faced with High Pressure Laminate with post-forming to horizontal edges of under panels. Vertical edges are lipped with ABS. Maximum single HPL vanity unit length is 2770mm.

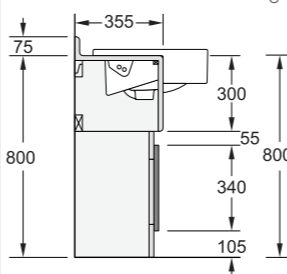

**K1 Profile**  
Semi-recessed basin with upstand.

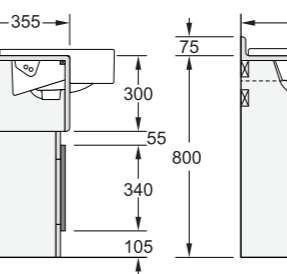

**K2 Profile**  
Semi-recessed basin without upstand.

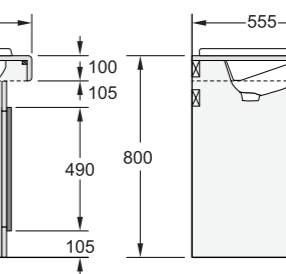

**K3 Profile**  
Fully inset basin with upstand.

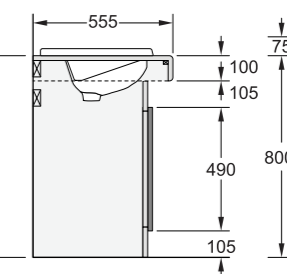

**K4 Profile**  
Fully inset basin without upstand.

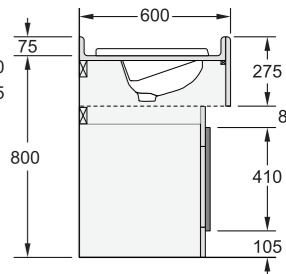

**Baby Change Profile**  
Fully inset basin with upstand.

## SGL

Suitable for wet and heavy duty applications. 13mm nominal thickness with polished black radiused edges. SGL vanities come with powder coated aluminium extrusions in Satin Anodised Aluminium or Black Anodised Aluminium. Maximum single SGL vanity unit length is 2770mm.

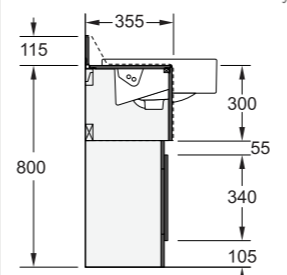

**CV1 Profile**  
Semi-recessed basin with upstand.

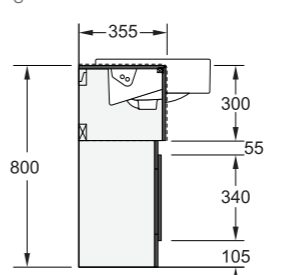

**CV2 Profile**  
Semi-recessed basin without upstand.

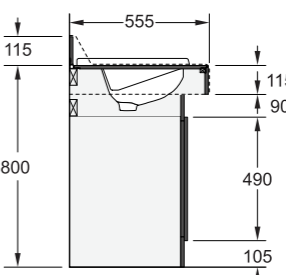

**CV3 Profile**  
Fully inset basin with upstand.

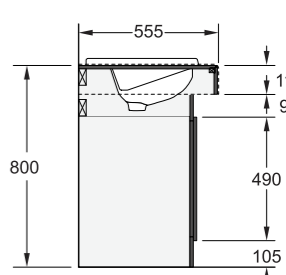

**CV4 Profile**  
Fully inset basin without upstand.

## Quartz

Maximum single Quartz vanity length is 2400mm.

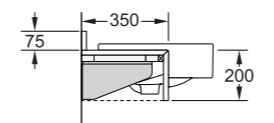

**Q1 Profile**  
Semi-recessed basin with upstand.

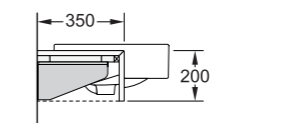

**Q2 Profile**  
Semi-recessed basin without upstand.

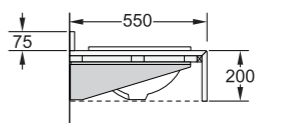

**Q3 Profile**  
Fully inset basin with upstand.

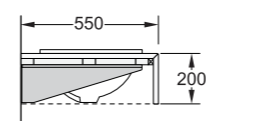

**Q4 Profile**  
Fully inset basin without upstand.

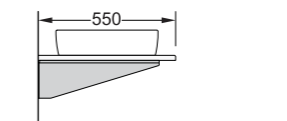

**Q5 Profile**  
Vessel basin without upstand.

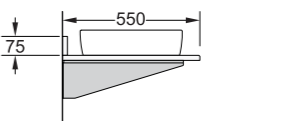

**Q6 Profile**  
Vessel basin with upstand.

## Light Pelmet

All fixing brackets included. Broken line indicates return end detail.

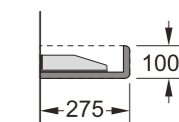

**LP3 Profile HPL Pelmet**

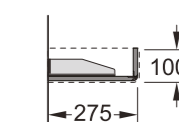

**LP6 Profile SGL Pelmet**

**Accessories** To complement your washroom, we've designed an inspiring range of accessories. From premium right through to budget, we promise you an accessory that's right for you.



# Accessories

Contemporary designs that do the job perfectly - that's our accessory range. To make your life easier, we have everything from soap dispensers and bins to door signs and coat hooks. It's all here ready for your selection.



#### Liquid soap dispenser

White metal

Wall mounted white metal liquid soap dispenser with key lock and 900ml refillable reservoir.

H251 x W108 x D91mm

Code: 0302521



#### Liquid soap dispenser

Stainless steel

Wall mounted stainless steel liquid soap dispenser with brushed satin finish, key lock and 900ml refillable reservoir.

H251 x W108 x D91mm

Code: 0302525



#### Liquid soap dispenser

Grey plastic

Wall mounted dispenser for liquid soap with Grey ABS case and stainless steel cover with 900ml refillable reservoir.

H255 x W130 x D120mm

Code: 0302513

#### Foam soap dispenser

Grey plastic

Wall mounted dispenser for foam soap with Grey ABS case and stainless steel cover with 900ml refillable reservoir.

H255 x W130 x D120mm

Code: 0302514



#### Liquid soap dispenser

White plastic

Wall mounted dispenser for liquid soap with white ABS case and 900ml refillable reservoir.

H250 x W115 x D115mm

Code: 0302540



#### Liquid soap dispenser

Polished chrome

Basin or vanity mounted liquid soap dispenser with polished chrome finish and 900ml refillable soap bottle.

H85 x Ø44 x L140mm

Code: 0302532



#### Under mounted basin liquid soap dispenser

Polished chrome

Liquid soap dispenser in polished chrome finish with 500ml soap bottle for basins mounted under vanity top.

H60 x W105 x Ø50mm

Code: 0302014



#### Top mounted basin liquid soap dispenser

Polished chrome

Liquid soap dispenser in polished chrome finish with 500ml soap bottle and spacer ring for basins mounted on vanity top.

H80 x W105 x Ø50mm

Code: 0302015



#### Cylindrical liquid soap dispenser

Stainless steel

Wall mounted stainless steel cylindrical soap dispenser with brushed satin finish.

H193 x Ø63 x D88mm

Code: 0302508



#### Paper towel dispenser

White plastic

Wall mounted white ABS dispenser for C-fold or interfold paper towels.

H425 x W290 x D145mm

Code: 0302537



#### Paper towel dispenser

White metal

Wall mounted metal dispenser in white powder coated finish with key lock. Suitable for C-fold or interfold paper towels.

H300 x W262 x D128mm

Code: 0302522



#### Paper towel dispenser

Stainless steel

Wall mounted stainless steel dispenser in brushed satin finish with key lock. Suitable for C-fold or interfold paper towels.

H300 x W262 x D128mm

Code: 0302526



#### Paper towel dispenser

Black/Light Grey plastic

Wall mounted dispenser made from Black/Light Grey ABS with stainless steel cover. Suitable for C-fold or interfold paper towels.

H325 x W325 x D150mm

Code: Black trim 0302560

Light Grey trim 0302519



#### Behind mirror paper towel dispenser

Stainless steel

Behind mirror mounted stainless steel dispenser with hinged dispensing flaps. Suitable for interfold paper towels.

H464 x W292 x D107mm

Code: 0302531



#### Elite paper towel dispenser

Stainless steel

Recessed mounted stainless steel dispenser in brushed satin finish with door and key lock. Suitable for C-fold or interfold paper towels.

H510 x W340 x D118mm

Code: 0302045



#### Toilet seat sanitiser

Stainless steel

A compact sanitiser unit with a high quality brushed stainless steel finish.

H196 x W98 x D97mm

Code: 0302501

# Accessories



### Paper towel 30 litre waste bin

Stainless steel  
Floor standing stainless steel paper towel waste bin with brushed satin finish, bag holder and wall fixings.  
H527 x W344 x D161mm  
**Code: 0302528**



### Paper towel 50 litre waste bin

Stainless steel  
Floor standing stainless steel paper towel waste bin with brushed satin finish, bag holder and wall fixings.  
H602 x W301 x D301mm  
**Code: 0302529**



### Elite paper towel waste bin

Stainless steel  
Recessed mounted stainless steel paper towel waste bin with brushed satin finish, door latch and integral plastic liner.  
H835 x W340 x D118mm  
**Code: 0302046**



### Lockable toilet roll holder

Light/Dark Grey plastic  
Nylon single toilet roll holder with lockable arm and concealed wall fixings. Available in Light Grey or Dark Grey.  
H130 x W155 x D25mm  
**Code: Light Grey 0300403**  
**Dark Grey 0300147**



### Toilet roll holder

Light/Dark Grey plastic  
Nylon single toilet roll holder with concealed wall fixings. Available in Light Grey or Dark Grey.  
H130 x W155 x D25mm  
**Code: Light Grey 0300303**  
**Dark Grey 0300146**



### Single toilet roll holder

Stainless steel  
Stainless steel single toilet roll holder with concealed wall fixings.  
H85 x W141 x D40mm  
**Code: 0302509**



### Double toilet roll holder

Stainless steel  
Stainless steel double toilet roll holder with concealed wall fixings.  
H85 x W254 x D40mm  
**Code: 0302510**



### Jumbo toilet roll dispenser

Stainless steel  
Wall mounted stainless steel jumbo toilet roll dispenser with brushed satin finish, key lock and viewing slot.  
Ø320 x H320 x D125mm  
**Code: 0302500**



### Jumbo toilet roll dispenser

White metal  
Wall mounted white powder coated metal jumbo toilet roll dispenser with key lock and viewing slot.  
Ø320 x H320 x D125mm  
**Code: 0302523**



### Midi-jumbo toilet roll dispenser

Black plastic  
Wall mounted jumbo toilet roll dispenser in Black ABS case and stainless steel cover, with spare stub roll.  
H350 x W260 x D140mm  
**Code: 0302518**



### Midi-jumbo toilet roll dispenser

White plastic  
Wall mounted white ABS jumbo toilet roll dispenser.  
H325 x W280 x D145mm  
**Code: 0302538**



### Toilet tissue dispenser

White plastic  
Wall mounted white ABS toilet tissue dispenser.  
H275 x W150 x D130mm  
**Code: 0302539**



### Slimline warm air hand dryer

Stainless steel  
Surface mounted slimline warm air hand dryer, with low energy twin blowers and touch-free start/stop sensors.  
H345 x W350 x D100mm  
**Code: 0302520**



### Automatic high speed hand dryer

Metallic silver  
Compact high speed hand dryer with low energy consumption, touch-free start/stop sensor and metallic silver cast aluminium cover.  
H300 x W280 x D175mm  
**Code: 0302535**



### Automatic high speed hand dryer

White metal  
Compact high speed hand dryer with low energy consumption, touch-free start/stop sensor and white cast aluminium cover.  
H300 x W280 x D175mm  
**Code: 0302533**



### Automatic jet hand dryer

Metallic silver  
High speed jet hand dryer with metallic silver ABS cover, auto start/stop sensors and low energy consumption.  
H670 x W300 x D219mm  
**Code: 0302536**



### Automatic jet hand dryer

White  
High speed jet hand dryer with white ABS cover, auto start/stop sensors and low energy consumption.  
H650 x W292 x D250mm  
**Code: 0302534**



### Back support rail

Satin stainless steel  
Aluminium back rest 400mm long with brushed satin stainless steel finish, concealed fixings and white vinyl pad.  
W400 x D310 x Ø35mm  
**Code: Rail only S6466MY**  
**Pad only S688467**



### Back support rail

White  
Aluminium back rest 400mm long with white polyester coated finish, concealed fixings and white vinyl pad.  
W400 x D310 x Ø35mm  
**Code: Rail only S6466AC**  
**Pad only S688467**



### 800mm hinged grab rail

Powder coated stainless steel  
Doc M and HBN compliant 800mm hinged grab rail with concealed fixings.  
W800 x Ø35mm  
**Code: White GRAB203**  
**Blue GRAB206**  
**Light Grey GRAB209**  
**Dark Grey GRAB212**



### Hinged support rail

Stainless steel  
Support rail in polished stainless steel with hinged support arm 800mm long and concealed fixing plate.  
L800 x H242 x W110mm  
**Code: S6360MY**



### Hinged support rail

White  
Support rail in white with hinged support arm 800mm long and concealed fixing plate.  
L800 x H242 x W110mm  
**Code: S6360AC**

# Accessories



**Toilet brush and holder**  
Stainless steel  
Wall mounted stainless steel toilet brush and holder in brushed satin finish.  
H396 x W89 x D115mm  
**Code: 0302512**



**Cubicle door pull handle**  
Satin anodised aluminium  
Pull door handle(s) in satin anodised aluminium.  
L400 x D45 x Ø19mm  
**Code: Single 0182225**



**Cubicle door pull handle**  
Satin stainless steel  
Pair of stainless steel pull door handles with brushed satin finish and concealed fixings.  
H619 x Ø19 x D65mm  
**Code: Pair 0302511**



**Cubicle door pull handle**  
Satin stainless steel  
Stainless steel cubicle door pull handle(s) with satin finish and concealed fixings.  
L225 x D45 x Ø19mm  
**Code: Single 0182221**  
**Pair 0182218**



**Cubicle door pull handle**  
Satin stainless steel  
Stainless steel cubicle door pull handle(s) with satin finish and concealed fixings.  
L400 x D45 x Ø19mm  
**Code: Single 0182216**  
**Pair 0182232**



**Cubicle door pull handle**  
Polished aluminium  
Pair of polished aluminium cubicle door handles with a polished anodised powder coated finish.  
H175 x W150 x D80mm  
**Code: Pair 0500101**



**600mm grab rail/fixing kit**  
White  
Aluminium grab rail 600mm long with white polyester coated finish and concealed fixings. Fixing plate kit for cubicle mounted grab rails.  
W600 x D95 x Ø80/Ø32  
**Code: Single S6454AC**  
**Fixing kit 0500021**



**600mm grab rail/fixing kit**  
Polished aluminium  
Polished aluminium grab rail 600mm long with concealed fixings. Fixing plate kit for cubicle mounted grab rails.  
W600 x D95 x Ø80/Ø32  
**Code: Single S6454MY**  
**Fixing kit 0500021**

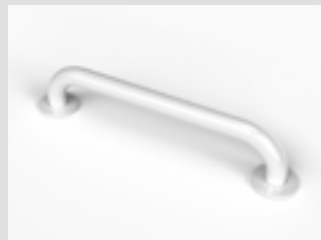

**455mm straight grab rail**  
Powder coated stainless steel  
Doc M and HBN compliant  
445mm grab rail with concealed fixings.  
W455 x Ø35mm  
**Code: White GRAB201**  
**Blue GRAB204**  
**Light Grey GRAB207**  
**Dark Grey GRAB210**

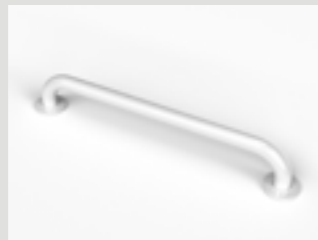

**600mm straight grab rail**  
Powder coated stainless steel  
Doc M and HBN compliant  
600mm grab rail with concealed fixings.  
W600 x Ø35mm  
**Code: White GRAB202**  
**Blue GRAB205**  
**Light Grey GRAB208**  
**Dark Grey GRAB211**



**Single coat hook**  
White plastic  
Nylon lightweight single coat hook in White with concealed fixings.  
H50 x W20 x D38mm  
**Code: 0300201**



**Single coat hook**  
Light Grey plastic  
Nylon lightweight single coat hook in Light Grey with concealed fixings.  
H50 x W20 x D38mm  
**Code: 0300139**



**Single coat hook**  
Dark Grey plastic  
Nylon lightweight single coat hook in Dark Grey with concealed fixings.  
H50 x W20 x D38mm  
**Code: 0300137**



**Single coat hook 65mm**  
Stainless steel  
Contemporary stainless steel single coat hook with concealed fixings and precision made groove retained buffer.  
Load tested to 30kg.  
Ø50 x D65mm  
**Code: MFC/HPL/CC CH65T**  
**SGL CH65SG**



**Single coat hook 90mm**  
Stainless steel  
Contemporary stainless steel single coat hook with concealed fixings and precision made groove retained buffer.  
Load tested to 30kg.  
Ø50 x D90mm  
**Code: MFC/HPL/CC CH90T**  
**SGL CH90SG**



**Male WC door sign**  
Stainless steel  
Stainless steel self adhesive male WC door sign.  
Ø76mm  
**Code: 0302563**



**Female WC door sign**  
Stainless steel  
Stainless steel self adhesive female WC door sign.  
Ø76mm  
**Code: 0302564**



**Unisex WC door sign**  
Stainless steel  
Stainless steel self adhesive unisex WC door sign.  
Ø76mm  
**Code: 0302565**



**Disabled WC door sign**  
Stainless steel  
Stainless steel self adhesive disabled WC door sign.  
Ø76mm  
**Code: 0302566**



**Baby change WC door sign**  
Stainless steel  
Stainless steel self adhesive baby change WC door sign.  
Ø76mm  
**Code: 0302567**



# We know our responsibility.

## Your world is our world. At Venesta, we treat the environment the way we treat our customers, with care and commitment.

### Managing our waste

#### Targeting zero waste

Waste is an inevitable part of any manufacturing process, but there are ways to ensure it doesn't become an environmental headache. In 2016 we set ourselves a challenge to reduce and if possible, totally eliminate our waste.

We are incredibly proud to say that in 2019 we became the first UK washroom manufacturer to achieve our target of 0% board waste to landfill.

A £1M investment into a new, state-of-the-art 1.75MW biomass burner has enabled us to eliminate MDF and HPL board waste; our smaller burner incinerates non-biomass waste like Solid Grade Laminate.

The cost of energy and the issue of carbon emissions are high on our environmental agenda and we are continually searching for ways to reduce energy consumption. Our biomass facility generates enough renewable energy to independently heat our entire manufacturing facility and office buildings.

We know our responsibility and Venesta is totally committed to making a positive impact on the environment. We treat the environment the way we treat our customers, with care and commitment.

### FSC® certification

#### Take care of the forest

As our customer, you can be confident that our materials and products have been checked at every stage of processing to ensure we are sourcing from sustainable and ethical sources.

We only purchase wood-based panel products from suppliers who are independently certified from either FSC (Forest Stewardship Council) or PEFC (Programme for the Endorsement of Forest Certification).

Our V3 Veneer range is FSC MIX certified with a full chain of custody available for our customers.

Laminate product materials are supplied to us as an FSC accredited product under 'FSC Controlled Wood'. Certificates are available to our customers upon request to demonstrate this.

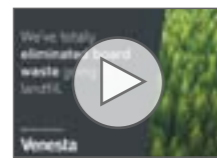

Learn about our biomass burner which has helped us achieve 0% board waste going to landfill by watching our dedicated video on our YouTube channel.

### Reducing our travel

#### Decreasing carbon emissions

As part of our ongoing commitment to improve our carbon footprint, we've tasked ourselves with reducing employees' travelling time. All staff are encouraged to use public transport wherever possible and we've installed video conferencing facilities on all of our sites to allow meetings to be held without the need for travel.



The mark of responsible forestry  
FSC® C137315



### 01-02 Waste management

Biomass burner turns production waste into factory and office heating.

### 03 Recycling

Wherever possible, all off-cuts are worked back into production for smaller product components.

### 04 Boilers

Our biomass burner has helped us achieve our 0% waste to landfill target.

### 05 Efficiency

Robotic handling systems ensure maximum board utilisation is achieved.

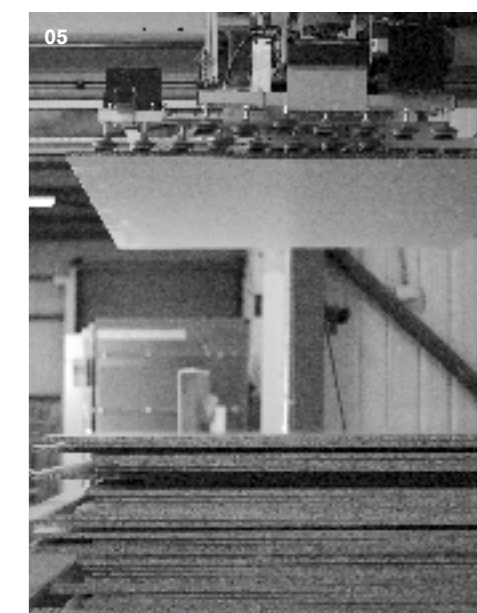

# We know washrooms. Your partner, every step of the way.

Venesta is passionate about ensuring you get the very best product and service, whatever the size of the project. That's why, from your first enquiry through to installation and beyond, you'll have a team of talented and committed experts working tirelessly to ensure you're happy and satisfied.

At Venesta, we believe it's our people that make the real difference to our business success. Everyone is an expert in their field, from our highly creative CAD team to our efficient and responsive Project Managers and our dedicated manufacturing team. Their experience and professionalism is what underpins the quality of our customer relationships.

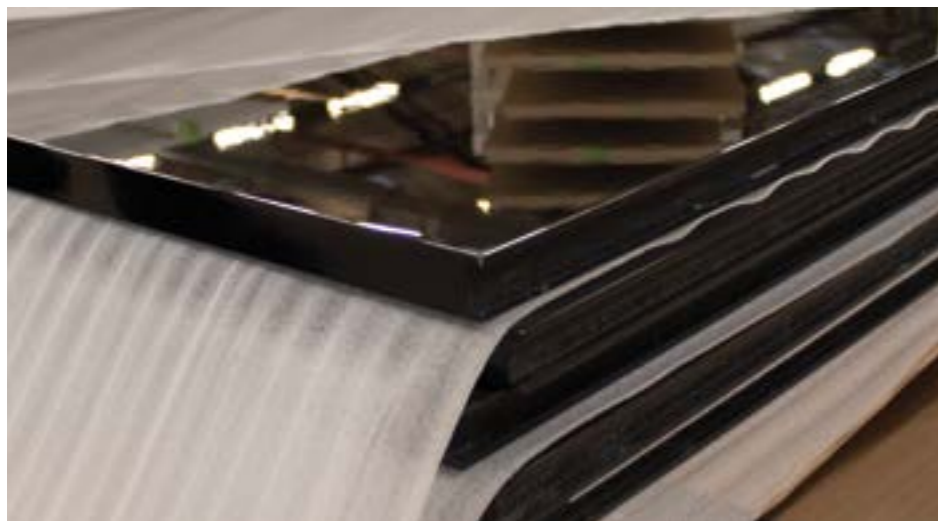

## How can we help you?

Our friendly and knowledgeable team is waiting to advise you on your project. Call us on **01474 353333**.

Alternatively, you can see all our products online at [www.venesta.co.uk](http://www.venesta.co.uk). We look forward to working with you.



**[www.venesta.co.uk](http://www.venesta.co.uk)**

**For help and advice on choosing  
your washroom, visit our website  
for a comprehensive guide.**

**Sales Office**

1st Floor, Units 19-23  
St George's Square  
St George's Centre  
Gravesend  
Kent, DA11 0TA  
United Kingdom

**London Showroom**

The Washroom Design Centre by Venesta  
80 Goswell Road  
London  
EC1V 7DB  
United Kingdom

Telephone  
+44 (0) 1474 353333

Email  
[marketing@venesta.co.uk](mailto:marketing@venesta.co.uk)

Republic of Ireland  
Telephone  
1 800 931 880

Middle East  
Telephone  
+971 6 5533361

[www.venesta.co.uk](http://www.venesta.co.uk)

[www.venesta-international.co.uk](http://www.venesta-international.co.uk)

[www.venesta-spares.co.uk](http://www.venesta-spares.co.uk)